

TT1200A
101-00930
101-00930-OH58D

Turbine Temperature Test Set

USER INSTRUCTION MANUAL
BARFIELD M/N TT1200A
BARFIELD P/N 101-00930
BARFIELD M/N OH-58D
BARFIELD P/N 101-00930-OH58D

56-101-00930
Revision F
September 25, 2014

BARFIELD, INC.

Corporate Headquarters
4101 Northwest 29th Street
Miami, Florida 33142
www.barfieldinc.com
Email: gsales@barfieldinc.com

CONTACT INFORMATION

Users are requested to notify the manufacturer of any discrepancy, omission, or error found in this manual. Inquiries should include specific questions and reference the publication title, number, chapter, page, figure, paragraph, and effective date.

Please send comments to:

**TECHNICAL CUSTOMER SUPPORT - GSTE
BARFIELD, INC.
P.O. BOX 025367
MIAMI, FL 33102-5367
USA**

Telephone **(305) 894-5400
(800) 321-1039**

Fax **(305) 894-5401**

Email gsesales@barfieldinc.com

ATTENTION

Although every effort has been made to provide the end user of this equipment with the most current and accurate information, it may be necessary to revise this manual in the future. Please be sure to complete and return the enclosed **OWNER WARRANTY REGISTRATION CARD** to Barfield in order to validate the warranty and to ensure that you will receive updated information when published. You MUST have your name and address on file at Barfield as a registered user of this equipment, to be able to obtain the service covered by the warranty.

Visit the company website, <http://barfieldinc.com/>, for publication updates.

Please send the Registration Card to:

Barfield, Inc.
P.O. Box 025367
Miami, FL 33102-5367
USA

REVISION RECORD

REV.	ECO #	REV. DATE	DESCRIPTION OF CHANGE
A	N/A	Feb. 28, 2003	Initial Release
B	260-00722	May 9, 2008	Specifications, Company Contact Information, and Logo were Updated. Chapters and Sections were reorganized.
C	260-00807	November 16, 2010	Update style; add the note that this also relates to M/N OH-58D.
D	260-00829	April 12, 2011	Updated warranty information.
E	260-00914	May 21, 2012	Updated recertification to include 101-00930-OH58D
F	260-01033	September 25, 2014	Updated Barfield logo & warranty info

MAINTENANCE AND REPAIR INFORMATION

The manufacturer of this equipment does not recommend the user to attempt any maintenance or repair. In case of malfunction, contact the manufacturer, to obtain the list of approved repair facilities worldwide, ensuring that this equipment will be serviced using proper procedures and certified instruments.

BARFIELD PRODUCT SUPPORT DIVISION

Telephone (305) 894-5400
(800) 321-1039

Fax (305) 894-5401

Shipping Address:

Barfield, Inc.
4101 NW 29th Street
Miami, Florida 33142
USA

Mailing Address:

Barfield, Inc.
P.O. Box 025367
Miami, FL 33102-5367
USA

TABLE OF CONTENTS

Contact Information
Attention Page
Revision Record
Maintenance and Repair Information
Table of Contents
List of Figures

	<u>PAGE</u>
INTRODUCTION	1
1. PUBLICATION BREAKDOWN.....	1
2. INFORMATION PROVIDED WITH THE UNIT	1
3. RECERTIFICATION	3
CHAPTER 1: DESCRIPTION	5
1.1. PURPOSE OF THIS MANUAL AND THE TEST SET.....	5
1.2. GENERAL DESCRIPTION.....	5
1.3. SWITCH DESCRIPTIONS AND FEATURES.....	7
CHAPTER 2: SPECIFICATIONS AND CAPABILITIES	11
2.1. SPECIFICATIONS	11
2.2. CAPABILITIES	12
CHAPTER 3: OPERATION	13
3.1. GENERAL OPERATING INSTRUCTIONS	13
A. Protective Circuits	13
B. Battery Installation and Verification	13
C. Precautions	13
D. Hot Engine Testing	14
E. Setting the System Resistance	14
3.2. POWER UP (INITIALIZATION).....	15
3.3. MENU DISPLAYS.....	16

TABLE OF CONTENTS (Continued)

	<u>PAGE</u>
CHAPTER 4: TEST PROCEDURES	17
4.1. MOVING-COIL-TYPE INDICATORS TEST PROCEDURES	17
A. System Lead Resistance Test Procedure.....	17
B. Thermocouple Resistance Test Procedure	18
C. Insulation Test Procedure.....	19
D. Indicator Test Procedure (With Specified Lead Resistance).....	19
E. Temperature Measurement Test Procedure.....	20
4.2. POTENTIOMETRIC OR SERVO-TYPE INDICATOR TEST PROCEDURE (Without Lead Resistance)	21
A. General	21
B. System Lead Resistance Measurement	22
C. Thermocouple Resistance Measurement	22
D. Insulation Testing.....	22
E. Indicator Test	22
F. Temperature Measurement.....	23
CHAPTER 5: RECEIVING, SHIPPING AND STORAGE	25
5.1. RECEIVING	25
5.2. SHIPPING	25
5.3. STORAGE.....	25

LIST OF FIGURES

	<u>PAGE</u>
Figure 1. Identification Label.....	1
Figure 2. Limited One Year Warranty	3
Figure 3. TT1200A Test Set	5
Figure 4. TT1200A Front Panel and Function Switches	7
Figure 5. Power Up Message Display Sequence	15
Figure 6. Display Menu Flowchart.....	16

This page intentionally left blank.

INTRODUCTION

1. PUBLICATION BREAKDOWN

This user instruction manual establishes the standards of operation for the Turbine Temperature Test Set.

Its purpose is to provide sufficient information for the personnel unfamiliar with this Tester to understand this equipment, identify its parts, and operate it in accordance with proper procedures, operating techniques, precautions and limitations.

2. INFORMATION PROVIDED WITH THE UNIT

Besides this User Instruction Manual, the Test Set is delivered with the items described below.

- A. The identification label, (Figure 1), located on the front of the Test Set, provides the following information:

	Manufacturer Name
	Designation of Equipment
	Equipment Part Number
Equipment Model Number	Equipment Serial Number
Equipment Modification (if applicable)	Equipment Options (if applicable)

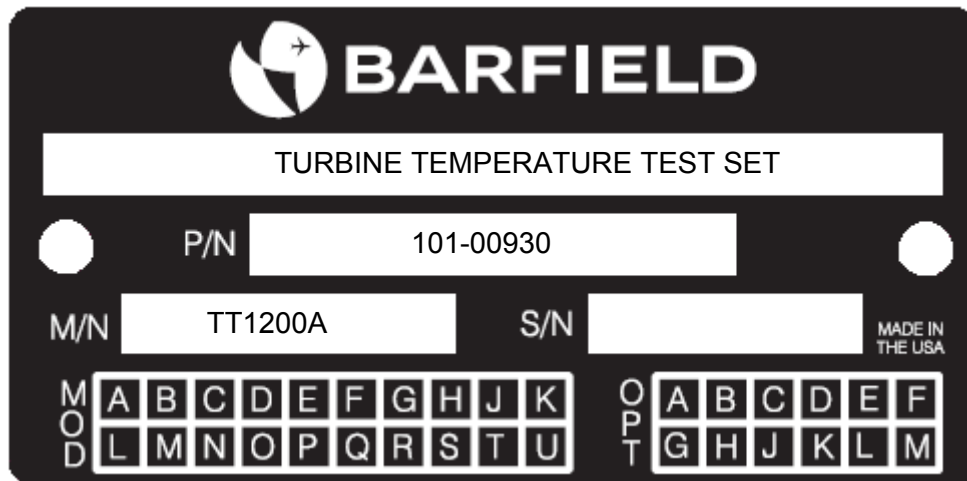

Figure 1 IDENTIFICATION LABEL

- B. Each new or re-certified unit is delivered with a Certificate that shows the date when the unit was tested by the manufacturer, its serial number, and when the next certification is due. This certificate confirms that the unit performed according to its design specifications.

3. RECERTIFICATION

The Test Set P/N 101-00930 and 101-00930-OH58D has a one-year recertification requirement. Maintenance required by this unit must be performed by qualified technicians in a shop equipped with the necessary tooling and facilities.

LIMITED ONE YEAR WARRANTY

BARFIELD INC. ("BARFIELD") warrants only to the original Purchaser of this product from BARFIELD or an authorized distributor that this product will be free from defects in material and workmanship under normal use and service for one year after date of purchase. BARFIELD reserves the right, before having any obligation under this limited warranty, to inspect the damaged BARFIELD product, and all costs of shipping the BARFIELD product to BARFIELD for inspection shall be borne solely by the Purchaser. In order to recover under this limited warranty, Purchaser must make claim to BARFIELD within 60 days of occurrence, and must present acceptable proof of original ownership (such as a purchase order, invoice, warranty card registration, or other documentation BARFIELD deems acceptable) for the product. BARFIELD, at its option, shall repair or replace the defective unit covered by this warranty. Please retain the dated sales receipt as evidence of the original purchaser's date of purchase. You will need it for any warranty service. In order to keep this limited warranty in effect, the product must have been handled and used as prescribed in the instructions accompanying this product. This limited warranty does not cover any damage due to accident, misuse, abuse or negligence. This limited warranty is non-transferable and does not apply to any purchaser who bought the product from a reseller or distributor not authorized by BARFIELD, including but not limited to purchases from internet sites. This warranty does not affect any other legal rights you may have by operation of law. Contact BARFIELD at www.Barfieldinc.com or customer service at (305) 894-5506 for warranty service procedures.

DISCLAIMER OF WARRANTY

EXCEPT FOR THE LIMITED WARRANTY PROVIDED HEREIN, TO THE EXTENT PERMITTED BY LAW, BARFIELD DISCLAIMS ALL WARRANTIES, EXPRESS OR IMPLIED, INCLUDING ALL WARRANTIES OF MERCHANTABILITY AND/OR FITNESS FOR A PARTICULAR PURPOSE. TO THE EXTENT THAT ANY IMPLIED WARRANTIES MAY NONETHELESS EXIST BY OPERATION OF LAW, ANY SUCH WARRANTIES ARE LIMITED TO THE DURATION OF THIS WARRANTY. SOME STATES/PROVINCES DO NOT ALLOW LIMITATIONS ON HOW LONG AN IMPLIED WARRANTY LASTS, SO THE ABOVE LIMITATIONS MAY NOT APPLY TO YOU.

LIMITATION OF LIABILITY

REPAIR OR REPLACEMENT OF THIS PRODUCT, AS PROVIDED HEREIN, IS YOUR EXCLUSIVE REMEDY. BARFIELD SHALL NOT BE LIABLE FOR ANY SPECIAL, INCIDENTAL OR CONSEQUENTIAL DAMAGES, INCLUDING, BUT NOT LIMITED TO, LOST REVENUES, LOST PROFITS, LOSS OF USE OF SOFTWARE, LOSS OR RECOVERY OF DATA, RENTAL OF REPLACEMENT EQUIPMENT, DOWNTIME, DAMAGE TO PROPERTY, AND THIRD-PARTY CLAIMS, ARISING OUT OF ANY THEORY OF RECOVERY, INCLUDING WARRANTY, CONTRACT, STATUTORY OR TORT. NOTWITHSTANDING THE TERM OF ANY LIMITED WARRANTY OR ANY WARRANTY IMPLIED BY LAW, OR IN THE EVENT THAT ANY LIMITED WARRANTY FAILS OF ITS ESSENTIAL PURPOSE, IN NO EVENT WILL BARFIELD'S ENTIRE LIABILITY EXCEED THE PURCHASE PRICE OF THIS PRODUCT. SOME STATES/PROVINCES DO NOT ALLOW THE EXCLUSION OR LIMITATION OF INCIDENTAL OR CONSEQUENTIAL DAMAGES, SO THE ABOVE LIMITATION OR EXCLUSION MAYNOT APPLY TO YOU. THIS WARRANTY GIVES YOU SPECIFIC LEGAL RIGHTS AND YOU MAY ALSO HAVE OTHER RIGHTS THAT VARY FROM STATE TO STATE AND PROVINCE TO PROVINCE.

BARFIELD INC.

4101 NW 29th Street
Miami, Florida 33142, USA

Form 7.5.3-13
Dated 09/01/2014, Rev. 1



AIRFRANCE /
INDUSTRIES

KLM
Engineering &
Maintenance

Figure 2 LIMITED ONE YEAR WARRANTY

This page intentionally left blank.

CHAPTER 1: DESCRIPTION

1. PURPOSE OF THIS MANUAL AND THE TEST SET

This publication contains the description and the operating procedures for:

TT1200A, DIGITAL TURBINE TEMPERATURE TEST SET, P/N 101–00930
OH-58D, DIGITAL TURBINE TEMPERATURE TEST SET, P/N 101–00930-OH58D

The TT1200A is specifically designed to test and calibrate Chromel – Alumel (CH – AL) temperature indicating systems.

2. GENERAL DESCRIPTION

The TT1200A (Figure 3) provides the means for quickly troubleshooting aircraft temperature indicating systems. It has sufficient sensitivity and accuracy to test thermocouple and system resistance, insulation, and indicator calibration. It features portability, simplicity of operation, direct reading, and multifunctional versatility.



Figure 3 TT1200A TEST SET

The main features of the TT1200A are:

- (1) Microprocessor Based.
- (2) Backlit 16-character alphanumeric LCD, which provides readings with applicable units and instructional user prompts.
- (3) Specifically designed to meet all requirements for testing aircraft Chromel–Alumel (CH–AL) temperature measuring systems, providing an accurate display of thermocouple outputs in degrees Celsius ($^{\circ}\text{C}$), Fahrenheit ($^{\circ}\text{F}$) and Millivolt (mV).
- (4) Thermocouple and lead resistance measurements to $0.001\ \Omega$ and insulation measurements up to $200\ \text{M}\Omega$.
- (5) Simulates thermocouple outputs and system lead resistances from 2 to $25\ \Omega$.
- (6) Completely self-contained, self-monitoring, easily portable temperature and resistance measuring and simulating device for all CH–AL systems with the capability to bench test indicators.
- (7) Human engineered for maximum ease of operation.
- (8) Automatic ambient test point temperature correction.
- (9) Carrying Case features:
 - (a) Fabricated from high impact plastic.
 - (b) Provides a pouch for test lead storage.
 - (c) The lid contains a placard of short operating instructions for the experienced technician.

Note: It is recommended that the user read this manual through its entirety to become familiar with the TT1200A Test Set and use the placard instructions as a quick reference only. Additionally, it is advisable that the user reviews the specific aircraft system before performing any tests or checks (refer to the Aircraft Maintenance Manual).

- (10) Auto Detection of Cable Type: At power up, the TT1200A detects, identifies and displays the type of cable connected: Test Cable (if no cable is connected); a Standard Cable; or a Doubler Cable.
- (11) Color Coded Function Keypad: For ease of use, the TT1200A keypad is color-coded to indicate the function, setting, range, and/or mode (soft key) pairing.
- (12) Auto Off: To save battery power, this “automatic off” feature allows the user to set a turn off time period for the unit in 5-minute increments (up to 1 hour). (If auto off is disabled, the Test Set stays on until the batteries become low.)

3. SWITCH DESCRIPTIONS AND FEATURES

The functions of the front panel switches and components, identified in Figure 4, are as follows:

- (1) The **PWR** (power) pushbutton, when pressed, applies power to the TT1200A and begins the initialization process.

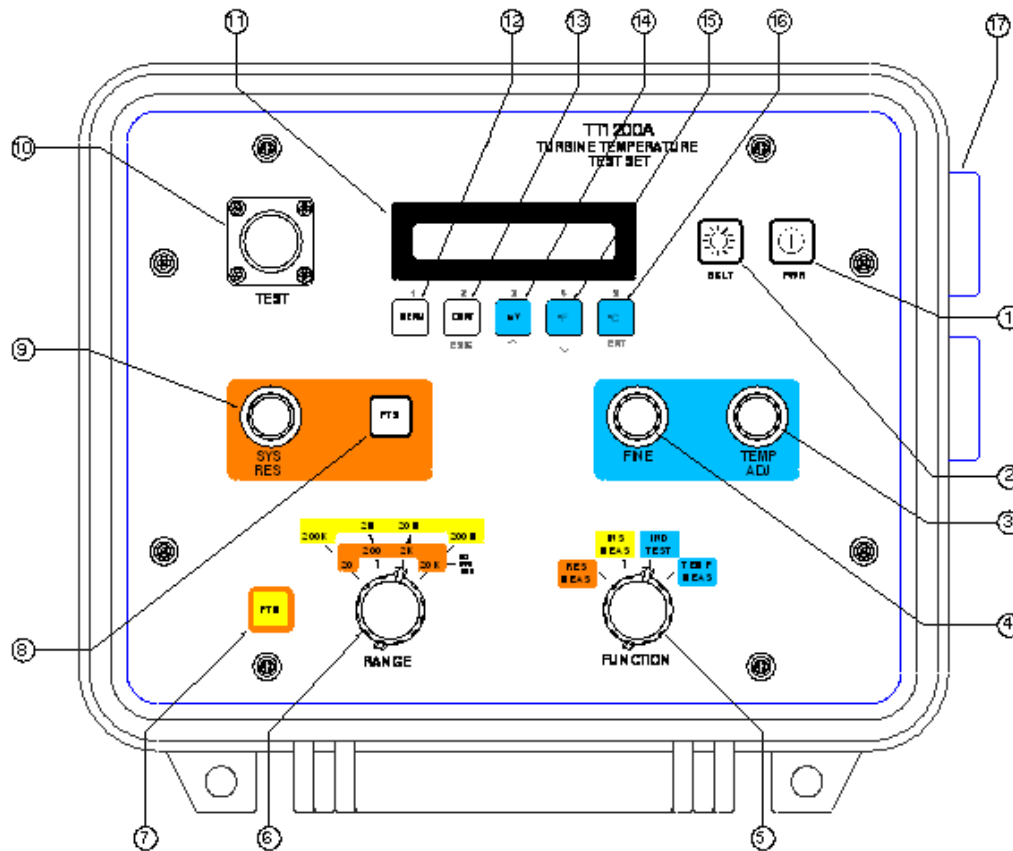

Figure 4 TT1200A FRONT PANEL AND FUNCTION SWITCHES

- (2) The **BKLT** (backlight) pushbutton, when pressed, provides a backlight to the LCD to improve readability under dim lighting conditions. A second press of the key turns the backlight off. (The backlight goes out automatically five minutes after activation to conserve batteries, unless the “BKLT auto-off” feature is disabled by pressing the BKLT pushbutton for 2 or more seconds.)
- (3) The **TEMP ADJ** control knob allows coarse adjustment of the temperature. When the FUNCTION is in the IND Test position, the display shows millivolt readings.
- (4) The **FINE** control provides exact adjustment of the temperature or millivolt readings shown on the display when the FUNCTION switch is in the IND TEST position.

- (5) The **FUNCTION** switch, is a four-position rotary switch that allows selection of the four main test functions:
- RES MEAS (Resistance Measure)
 - INS MEAS (Insulation Measure)
 - IND TEST (Indicator Test)
 - TEMP MEAS (Temperature Measure)
- (6) The **RANGE** switch is a four-position rotary switch that allows selection of the resistance and insulation ranges, 20 Ω , 200 Ω , 2K Ω and 20K Ω (for Resistance Measuring, RES MEAS), or 200K Ω , 2M Ω , 20M Ω and 200M Ω (for Insulation Measuring, INS MEAS.) The fourth position is also used for 0 Ω system resistance for the IND TEST function.
- (7) The **PTM** (Press To Measure) button, when pressed, activates the TT1200A excitation and measuring processes (when the FUNCTION switch is set to the RES MEAS or INS MEAS position).
- Note: While the TT1200A is processing the measurements, a flashing “M” appears on the right side of the display. When the process completes, a steady “H” replaces the ‘M’ on the display.
- (8) The **PTS** (Press To Set) button, when pressed, activates the SYS RES switch for system resistance adjustment. When PTS is held pressed in while rotating the SYS RES, the user may adjust resistance to the desired resistance setting.
- (9) The **SYS RES** (System Resistance) control knob is used to adjust system lead resistance from 2 to 25 Ω .
- (10) The **TEST** connector provides the means for connecting the TT1200A's standard leads or specifically designed interface cabling.
- (11) The **Display** is a 16-character alphanumeric LCD that shows the user prompts and all readings with associated units.
- (12) The **MENU** pushbutton when pressed causes the display to show the remaining available battery life (Battery ###%). In addition, the user may then use the soft keys mV (\uparrow) or $^{\circ}$ F (\downarrow) to scroll through display messages and option menus.*
- (13) The **CONT** pushbutton when held in and used with the soft keys mV (\uparrow) or $^{\circ}$ F (\downarrow), allows the user to adjust the display contrast level from 0 to 100. The pushbutton is also a soft key (ESC) to cancel a function and return the unit to normal operation.*

- (14) The **mV** (millivolt) pushbutton is a toggle which, when pressed, allows the user to select between two millivolt modes: mV and mV amb. When used with the MENU display, it is a soft key (\uparrow) to scroll through MENU selections. When used with the CONT pushbutton, the user may increase the display contrast.*

Note: The mV mode simulates a DVM function equivalent to having a DVM connected in parallel at the Test Set's red and black clips. The mV amb mode configures the TT1200A for ambient temperature compensation performed at the point of termination. The displayed millivolt is based on a reference junction at 0° C.

- (15) The **°F** (Fahrenheit) pushbutton is a toggle which allows selection between resolutions of 1 °F and 0.1 °F. The Display alternates between the resolutions with each button press. When used with the MENU key, the soft key (\downarrow) may be used to scroll to MENU selections. When used with the CONT pushbutton, the user may decrease the display contrast.*
- (16) The **°C** (Celsius) pushbutton is a toggle that allows selection between resolutions 1 °C and 0.1 °C. The Display alternates between resolutions with each button press. The pushbutton is also a soft key (ENT) to enter Menu confirmations.*

*Note: The soft keys (#12 through #16), may also be used as numeric keys when entering a password.

- (17) Two battery holders contain six (6) C-cell alkaline batteries that provide the power for all test set functions.
- (18) Standard Leads P/N 175-00215 for Test Set P/N 101-00930 or P/N 175-00217 for Test Set P/N 101-00930-OH58D.

This page intentionally left blank.

CHAPTER 2: SPECIFICATIONS AND CAPABILITIES

1. SPECIFICATIONS

A. Physical Data:

- (1) Height: 7.0 in 17.8 cm
- (2) Width: 11.0 in 27.9 cm
- (3) Depth: 10.0 in 25.4 cm
- (4) Weight: 7.3 lbs 3.3 kg

B. Temperature Measurement:

- (1) Type:K (CH–AL Thermocouple).
- (2) Range:-25° C to +1200° C (certified)
.....-50° C to +1372° C (extended)
- (3) Accuracy:Typical measurement error at 77° F (25° C) ambient:
less than $\pm 0.5^\circ$ C.
- (4) Ambient Operating Range:14° F to 122° F (-10° C to +50° C)

C. Lead Resistance:

- (1) Range:0-19.999 Ω in 0.001 Ω increments.
Range:0-199.99 Ω in 0.01 Ω increments.
Range:0-1.9999 k Ω in 0.0001 k Ω increments.
Range:0-19.999 k Ω in 0.001 k Ω increments.
- (2) Accuracy: $\pm 0.05\%$ of reading ± 2 counts

D. Insulation:

- (1) Range:0-199.9 k Ω in 0.1 k Ω increments.
Range:0-1.999 M Ω in 0.001 M Ω increments.
Range:0-19.99 M Ω in 0.01 M Ω increments.
Range:0-200 M Ω in 5 M Ω increments.
- (2) Accuracy: $\pm 5\%$ of reading ± 5 counts (200 k Ω , 2 M Ω , and 20 M Ω ranges).
..... $\pm 10\%$ of reading ± 5 counts (200 M Ω range).
- (3) Excitation:45 VDC nominal.

E. Simulated System Resistance:

(1) Adjustment Range:.....Less than 2.00 Ω to greater than 25.00 Ω .

(2) Fixed Setting.....Less than 0.01 Ω .

2. CAPABILITIES

A. Measures and displays resistance of thermocouples, thermocouple rings and system lead circuits.

B. Measures and displays insulation resistance of system wiring and other components.

C. Simulates CH-AL thermocouples with or without simulated system lead resistance.

D. Measures and displays values of CH—AL thermocouples in terms of millivolts, millivolts with ambient compensation, 1° F or 0.1° F, and 1° C or 0.1° C.

E. Automatically compensates for ambient temperature at test lead connection junction point or indicates this cold junction temperature.

CHAPTER 3: OPERATION

1. GENERAL OPERATING INSTRUCTIONS

Consult the temperature indicator system and/or engine manufacturer's instructions for procedures and specifications.

Note: It is recommended that the complete TT1200A Operation procedures be read before attempting to use the TT1200A.

A. Protective Circuits

Although the TT1200A has input protection, do not connect the test set to an energized circuit.

B. Battery Installation and Verification

- (1) Remove the covers from the battery holders located on the right side of the case. Lift the left side of the TT1200A so that the batteries slide out. Insert three (3) alkaline C-cell batteries into each holder with all positive terminals facing outward. Reattach the covers to each tube.
- (2) At power up the display shows the message "**Battery ###%**", to indicate the remaining available battery life.
- (3) The user may check battery condition at any time by pressing the MENU pushbutton.
- (4) When the available battery power goes below 15%, the Test Set displays the "Battery Low" message approximately every minute. When the available battery power goes below 7%, the T/S displays the "Battery Low" message every 30 seconds. In this case, replace the batteries as was described above.

C. Precautions

- (1) Do NOT press the PTM or PTS pushbuttons with test clips connected to the aircraft indicator. The applied current may damage the indicator.
- (2) Do NOT connect test clips to an energized circuit. Although the TT1200A is provided with protective devices, not all damaging potentials may be completely safe.
- (3) Allow sufficient time for test clips to stabilize to the temperature of the terminals to which they are connected for temperature tests.
- (4) For greatest accuracy, measure system and thermocouple resistance with a cold engine.
- (5) To conserve battery power, power down the Test Set when it is not in use.

- (6) The Test Set displays the message “Battery Low” indicating that the batteries should be replaced.

D. Hot Engine Testing

A hot engine causes thermocouples to generate a small potential *which produces errors* in measured resistance values. This effect is natural for any type of resistance measuring instrument.

The effect, however, can be avoided by taking two measurements:

1. With test leads connected in one polarity;
2. Reversing the lead connections for the second measurement.

Add the two readings and divide by two. (The true value is equal to the average of the two readings.) The two readings must be taken in quick succession so that the thermocouple temperature will be the same for both readings. If the thermocouples are too hot, the readings will be too far from nominal to provide sufficient accuracy. In this case, wait for the engine to further cool.

E. Setting the System Resistance

- (1) Short the test lead clips together.
- (2) Set the FUNCTION switch to RES MEAS.
- (3) Set the RANGE switch to 200Ω.
- (4) While pressing in the PTS pushbutton in, rotate the SYS RES knob to set the required system resistance for the specific aircraft-under-test (refer to the specific Aircraft Maintenance Manual).

Note: While the PTS button is held in, the TT1200A shows the message “PTS” on the right of the display.

- (5) Release the PTS button.

Note: The TT1200A replaces the message “PTS” with “SET” on the display.

2. **POWER UP (INITIALIZATION)**

At power up, the TT1200A displays a series of informational messages (Figure 5), including the unit’s software version (Ver ##.##.##.X); the available battery power percentage (Battery ###%) and the calibration due date (Cal. Due, mm/yyyy).

Note: If the calibration due date is less than 30 days before the calibration is needed, the message “Cal. In ## Days” displays. If the calibration due date has been exceeded, the unit displays “Cal Required”.

If no errors are detected during power up, the instrument enters normal mode. If the function switch is in the RES MEAS or INS MEAS position, the message "Push PTM" displays.

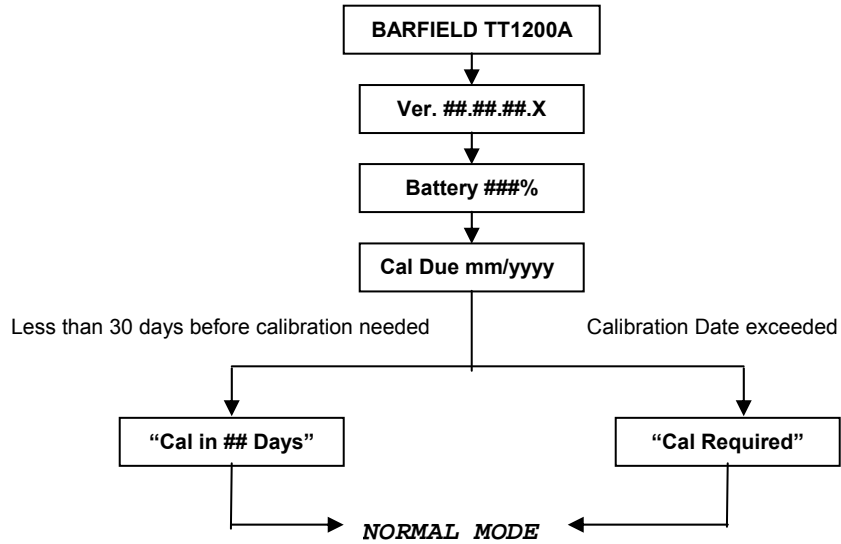

Figure 5 POWER UP MESSAGE DISPLAY SEQUENCE

3. MENU DISPLAYS

Once the MENU button is pressed, the user may use the **mV** (\uparrow) or the **°F** (\downarrow) soft keys to scroll through the message display and option menus as shown (Figure 6):

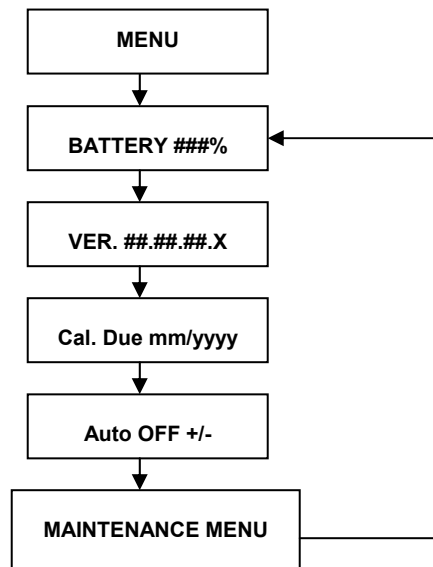

Figure 6 DISPLAY MENU FLOWCHART

- **Battery ###%**
The display shows the available battery power percentage available.
- **Ver. ##.##.##.X**
The display shows the current software version installed in the unit.
- **Cal Due mm/yyyy**
The display shows the month and year when calibration is due.
- **Auto Off**
This feature allows the user to set a time period for the unit to automatically turn off when not in use. To activate the feature: at the Auto +/- display, press ENT (°C). Use the mV or °F keys to set 5 minute increments (up to 60 minutes). Press ENT to accept entry. Press ESC to exit from Menu options.
- **Maintenance**
This menu option is password protected and allows other maintenance functions such as setting the calibration due date.

CHAPTER 4: TEST PROCEDURES

1. MOVING-COIL-TYPE INDICATOR TEST PROCEDURES

A. SYSTEM LEAD RESISTANCE TEST PROCEDURE

- (1) Access the aircraft system temperature indicator.
- (2) Disconnect thermocouple leads from the indicator.
- (3) Connect the standard leads to the Test Set's TEST connector.
- (4) Press the Test Set PWR pushbutton.
- (5) Set the FUNCTION switch to RES MEAS.
- (6) Set the RANGE switch to 200 Ω .

Note: The mV, °F and °C pushbuttons are inactive. The settings for the SYS RES, TEMP ADJ and FINE control knobs have no effect.

- (7) Carefully connect test lead clips to aircraft lead wires insuring a good electrical connection.
- (8) Connect the red clip to the chromel lead and the black clip to the alumel lead.
- (9) Press and release the PTM pushbutton.
- (10) Ensure that the display shows resistance in Ω with a 0.01 Ω resolution.
- (11) If display reads "OUT OF RANGE", the resistance is greater than 199.99 Ω or there is an open circuit.
- (12) Exchange the RED and BLACK test clip connections and verify the display repeats the same reading when the PTM pushbutton is pressed. If reading does not repeat, the engine thermocouples may be hot. (Refer to Hot Engine Testing, Chapter 3, section 1.D.).

Note: Resistance must be within the manufacturer's specifications. If results are slightly outside limits, repeat entire procedure to insure test failure is not due to human error.

- (13) Press the PWR pushbutton to power down the Test Set.
- (14) Disconnect the Test Set from the aircraft wiring.
- (15) Return the aircraft to its original configuration.

B. THERMOCOUPLE RESISTANCE TEST PROCEDURE

- (1) Access the aircraft thermocouple leads at the appropriate system break.
- (2) Disconnect the thermocouple leads from the aircraft wiring.
- (3) Connect the standard leads to the Test Set's TEST connector.
- (4) Press the Test Set PWR pushbutton.
- (5) Set the FUNCTION switch to RES MEAS.
- (6) Set the RANGE switch to 200 Ω .

Note: The mV, °F and °C pushbuttons are inactive. The settings for the SYS RES, TEMP ADJ and FINE switches have no effect.

- (7) Carefully connect the test lead clips to the aircraft lead wires insuring a good electrical connection.
- (8) The red clip connects to the chromel lead and the black clip to alumel lead.
- (9) Press and release the PTM pushbutton.
- (10) The display shows resistance in Ω with 0.01 Ω resolution.
- (11) If display reads "OUT OF RANGE", the resistance is greater than 199.99 Ω , or there is an open circuit.
- (12) Exchange the RED and BLACK test clip connections and verify that the display repeats the reading when the PTM pushbutton is pressed. If reading does not repeat, the engine thermocouples may be hot. (Refer to Hot Engine Testing, Chapter 3, section 1.D.).

Note: Resistance must be within the manufacturer's specifications. If results are slightly outside limits, repeat entire procedure to insure test failure is not due to human error.

- (13) Press the PWR pushbutton to power down the Test Set.
- (14) Disconnect the Test Set from the aircraft wiring.
- (15) Return the aircraft to its original configuration.

C. INSULATION TEST PROCEDURE

- (1) Access the aircraft system temperature indicator.
- (2) Disconnect one or both leads from the aircraft system indicator (refer to the engine manufacturer's Maintenance Manual for the specific test method).

- (3) Connect the standard leads to the Test Set's TEST connector.
- (4) Press the Test Set PWR pushbutton.
- (5) Set the FUNCTION switch to INS MEAS.
- (6) Set the RANGE switch to 2M Ω .

Note: The mV, °F and °C pushbuttons are inactive. The settings for the SYS RES, TEMP ADJ and FINE control knobs have no effect.

- (7) Connect the BLACK lead clip to the aircraft ground and the RED lead clip to one or both thermocouple system lead wires (refer to the engine manufacturers' Maintenance Manual for the specific connections).
- (8) Press and release PTM pushbutton.
- (9) The display shows the insulation resistance in 1,000,000's of ohms (M Ω).
- (10) If display reads "OUT OF RANGE", the resistance is greater than 1.999 M Ω or there is an open circuit.

Note: Resistance to ground must be no less than manufacturer's specifications.

- (11) Press the PWR pushbutton to power down the Test Set.
- (12) Disconnect the Test Set from the aircraft wiring.
- (13) Return the aircraft to the original configuration.

D. INDICATOR TEST PROCEDURE (With Specified Lead Resistance)

- (1) Access the aircraft system temperature indicator.
- (2) Disconnect the thermocouple leads from the indicator.
- (3) Connect the standard leads to the Test Set's TEST connector.
- (4) Press the Test Set PWR pushbutton.
- (5) Set the FUNCTION switch to RES MEAS.
- (6) Set the RANGE switch to 200 Ω .
- (7) Short the test lead clips together to insure a good electrical connection.
- (8) Press the PTS pushbutton while adjusting the SYS RES control knob for displayed system resistance to be simulated.
- (9) Release PTS pushbutton.

- (10) Set FUNCTION switch to IND TEST.
- (11) Press the mV, °F or °C pushbuttons to select units. Press the selected key again for mode (mV) or resolution (°F or °C).
- (12) Connect test lead clips to indicator terminals. Observe polarity: Alumel is negative (-) and connects to the TT1200A BLACK clip. Chromel is positive (+) and connects to the TT1200A RED clip.
- (13) Set the TEMP ADJ control knob for the desired test temperature as displayed on the TT1200A display indicator. It may be necessary to use the FINE control to achieve the exact settings.
- (14) Compare the readings of indicator under test with the TT1200A readings.

Note: Indicator must agree with TT1200A reading to within manufacturers' specifications.
- (15) Press the PWR pushbutton to power down the Test Set.
- (16) Disconnect the Test Set from the aircraft wiring.
- (17) Return the aircraft to its original configuration.

E. TEMPERATURE MEASUREMENT TEST PROCEDURE

- (1) Access the aircraft system temperature indicator.
- (2) Disconnect thermocouple leads from indicator.
- (3) Connect standard leads to Test Set's TEST connector.
- (4) Press the Test Set PWR pushbutton.
- (5) Set the FUNCTION switch to TEMP MEAS.
- (6) Set the RANGE switch to 20 K Ω - 0 Ω SYS RES.
- (7) Press the mV, °F or °C key to select units of measurements.

Caution: The aircraft indicators of the D'Arsonval-type must *not* be connected during this test. D'Arsonval indicators may generally be recognized by the absence of a multi-pin connector and usually have two terminal posts or terminal screws.

- (8) Connect test lead clips to indicator terminals. Observe polarity: Alumel is negative (-) and connects to the TT1200A BLACK clip. Chromel is positive (+) and connects to the TT1200A RED clip.
- (9) Verify that the display shows the thermocouple temperature in the desired unit as selected in step 7 above.

Note: If the message “OPEN T/C” displays, there is an open circuit in thermocouple or lead wires.

- (10) Press the PWR pushbutton and power down the Test Set.
- (11) Disconnect the Test Set from the aircraft wiring.
- (12) Return the aircraft to its original configuration.

2. POTENTIOMETRIC OR SERVO-TYPE INDICATOR TEST PROCEDURE (Without Lead Resistance)

A. GENERAL

- (1) The Potentiometric or Servo indicator may be recognized by its multiple pin electrical connector and the requirement of the aircraft electrical power to operate.
- (2) Thermocouple lead resistance is not critical with this type of indicator, and usually need not be measured.

B. SYSTEM LEAD RESISTANCE MEASUREMENT

- (1) Disconnect the aircraft power to indicator (refer to the Maintenance Manual).
- (2) Disconnect the electrical connector at the rear of indicator.
- (3) Connect the TT1200A leads to probe pins sized to fit the chromel and alumel pin sockets of the aircraft plug removed from indicator.
- (4) Follow the System Lead Resistance Test Procedure (Chapter 4, subsection 1.A), steps (3) through (11) and steps (13) through (15).

Note: Lead resistance is not critical, and can be from 5 to 100 Ω (refer to the Maintenance Manual for specific values).

C. THERMOCOUPLE RESISTANCE MEASUREMENT

- (1) Disconnect aircraft power to indicator (refer to the Maintenance Manual).
- (2) Follow the Thermocouple Resistance Test Procedure (Chapter 4, subsection 1.B) in its entirety.

D. INSULATION TESTING

- (1) Disconnect the aircraft power to the indicator (refer to the Maintenance Manual).
- (2) Disconnect the electrical connector at rear of indicator.
- (3) Connect the TT1200A leads to probe pins sized to fit the chromel and alumel pin sockets of aircraft plug removed from the indicator.
- (4) Follow the Insulation Test Procedure (Chapter 4, subsection 1.C), steps (3) to (13).

E. INDICATOR TEST

- (1) Disconnect the aircraft power to indicator (refer to the Maintenance Manual).
- (2) Access the aircraft engine thermocouple terminal block.
- (3) Disconnect the leads from indicator at engine thermocouple terminal block.
- (4) Connect the standard leads to Test Set's TEST connector.
- (5) Press the Test Set PWR pushbutton.
- (6) Set the FUNCTION switch to IND TEST.
- (7) Set the RANGE switch to 20 K Ω - 0 Ω SYS RES.

- (8) Press the mV, °F or °C key to select units of measurement.
- (9) Connect test lead clips to indicator leads. **OBSERVE POLARITY:** Alumel is negative (-) and connects to the TT1200A BLACK clip. Chromel is positive (+) and connects to the TT1200A RED clip. For the P/N 101-00930-OH58D connect the Green clip to aircraft chassis ground.
- (10) Place aircraft temperature indicating system power to ON.
- (11) Set TEMP ADJ control for the desired test temperature as shown on the TT1200A display. It may be necessary to use the FINE control to achieve the exact settings.
- (12) Compare the readings of indicator under test with TT1200A indications.

Note: Indicator must agree with TT1200A reading to within manufacturers' specifications.
- (13) Press PWR pushbutton to power down Test Set.
- (14) Disconnect Test Set from aircraft wiring.
- (15) Return the aircraft to its original configuration.

F. TEMPERATURE MEASUREMENT

- (1) Disconnect the aircraft power to indicator (refer to the Maintenance Manual).
- (2) Disconnect the electrical connector at the rear of indicator.
- (3) Connect standard leads to Test Set's TEST connector.
- (4) Press the Test Set PWR pushbutton.
- (5) Set the FUNCTION switch to TEMP MEAS.
- (6) Set the RANGE switch to 20 K Ω - 0 Ω SYS RES.
- (7) Press the mV, °F or °C key to select units of measurements.
- (8) Connect the TT1200A leads to probe pins sized to fit the chromel and alumel pin sockets of the aircraft plug removed from indicator. For the P/N 101-00930-OH58D connect the Green clip to aircraft chassis ground.
- (9) Verify that the display shows the thermocouple temperature in the desired unit as selected in step 7 above.

Note: If the message "OPEN T/C" displays, there is an open circuit in the thermocouple or in the lead wires.

- (10) Press the PWR pushbutton and power down the Test Set.
- (11) Disconnect the Test Set from the aircraft wiring.
- (12) Return the aircraft to its original configuration.

CHAPTER 5: RECEIVING, SHIPPING, AND STORAGE

1. RECEIVING

No special unpacking procedures are necessary. It is recommended that factory shipping container and packing materials be retained should it become necessary, for any reason, to reship the Test Set.

It is also recommended that the Test Set be carefully inspected for damage. If damaged, immediately notify both the carrier and manufacturer.

2. SHIPPING

Use standard delicate electronic equipment packaging procedures when packing the Test Set for reshipment.

3. STORAGE

Store in a cool dry place.