



DFQ40K Fuel Quantity Test Set

USER INSTRUCTION MANUAL BARFIELD M/N DFQ40K

*Doc. P/N: 56-101-01501_01502
Revision C
November 7, 2014*

BARFIELD, INC.

Manual applicable for DFQ40K P/Ns:

101-01501

101-01502

Corporate Headquarters

4101 Northwest 29th Street

Miami, Florida 33142

www.barfieldinc.com

Email: gsesales@barfieldinc.com

Barfield Inc. Confidential and Proprietary Information.

This document and all the information contained herein is the sole property of Barfield Inc.

No intellectual property rights are granted by the delivery of this document or the disclosure of its content.

*This entire document is **proprietary information** and shall **not** be reproduced or disclosed to a third party without the express written consent of Barfield Inc.*

This document and its content shall not be used for any purpose other than that for which it is supplied.

DFQ40K INSTRUCTION MANUAL

CONTACT INFORMATION

Users are requested to notify the manufacturer of any discrepancy, omission, or error found in this manual. Inquiries should include specific questions and reference the publication title, number, chapter, page, figure, paragraph, and effective date.

Please send comments to:

**TECHNICAL CUSTOMER SUPPORT - GSTE
BARFIELD, INC.
P.O. BOX 025367
MIAMI, FL 33102-5367
USA**

Telephone: **(305) 894-5400**
(800) 321-1039

Fax: **(305) 894-5401**

Email: techsupport.gste@barfieldinc.com

DFQ40K INSTRUCTION MANUAL

ATTENTION

Although every effort has been made to provide the end user of this equipment with the most current and accurate information, it may be necessary to revise this manual in the future. Please be sure to complete and return the enclosed **OWNER WARRANTY REGISTRATION CARD** to Barfield in order to validate the warranty and to ensure that you will receive updated information when published. You MUST have your name and address on file at Barfield as a registered user of this equipment, to be able to obtain the service covered by the warranty.

Visit the company website, <http://barfieldinc.com/>, for publication updates.

Please send the Registration Card to:

Barfield, Inc.
P.O. Box 025367
Miami, FL 33102-5367
USA

DFQ40K INSTRUCTION MANUAL

DISCLAIMER

BARFIELD, INC., neither a vendor nor supplier of fuel quantity indicating systems or an airframe manufacturer, has no control over testing and calibration values and procedures. The Aircraft Maintenance Manual shall be the first source of information regarding testing and calibration values and procedures, taking precedence over this manual. A variant between actual values and procedures and those recommended in this manual may exist. However, the information presented here is correct to the best of our knowledge at time of publication and is presented for reference only.

DFQ40K INSTRUCTION MANUAL

REVISION RECORD

REV.	ECO #	REV. DATE	DESCRIPTION OF CHANGE
A	N/A	Jan/20/2010	Initial Release
B	260-00780	May/25/2010	Some notes at Fig. A1, "Operation Displays Navigation Guide" (pag. 37), were reworded
C	260-01054	Nov / 7 / 2014	Updated Barfield logo



DFQ40K INSTRUCTION MANUAL

LIST OF APPROVED REPAIR FACILITIES

The manufacturer of this equipment does not recommend the user to attempt any maintenance or repair. In case of malfunction, contact the manufacturer, to obtain the list of approved repair facilities worldwide, ensuring that this equipment will be serviced using proper procedures and certified instruments. A Return Maintenance Authorization (RMA) number will be assigned during this call, to keep track of the shipment and the service.

BARFIELD PRODUCT SUPPORT DIVISION

Telephone: (305) 894-5400
(800) 321-1039

Fax: (305) 894-5401

Email: gsesales@barfieldinc.com

Shipping Address:

Barfield, Inc.
4101 NW 29th Street
Miami, Florida 33142
USA

Mailing Address:

Barfield, Inc.
P.O. Box 025367
Miami, FL 33102-5367
USA

TABLE OF CONTENTS

Contact Information
Attention Page
Disclaimer Page
Revision Record Page
List of Approved Repair Facilities
Table of Contents
List of Figures

<u>CHAPTER</u>		<u>PAGE</u>
	<u>INTRODUCTION</u>	
	1. PUBLICATION BREAKDOWN	1
	2. INFORMATION PROVIDED WITH THE UNIT	1
	3. RECERTIFICATION	3
1	<u>GENERAL INFORMATION</u>	
	1. DESCRIPTION AND PURPOSE OF THE TEST SET	5
	2. TEST SET FEATURES	6
	3. BATTERIES AND ACCESSORIES INFORMATION	10
2	<u>SPECIFICATIONS</u>	
	1. TEST SET SPECIFICATIONS.....	13
	2. PHYSICAL DATA	14
	3. OPERATING TEMPERATURE RANGE.....	14
3	<u>OPERATION</u>	
	1. AIRCRAFT INSULATION TEST	15
	2. AIRCRAFT CAPACITANCE TEST	17
	3. INDICATOR TEST	20
	4. SYSTEM CALIBRATION, PREFERRED (DRY TANK)	23
	5. SYSTEM CALIBRATION, ALTERNATE (WET TANK).....	26
	6. BENCH TEST PROBE INSULATION	28
	7. BENCH TEST PROBE CAPACITANCE	30
4	<u>RECEIVING, SHIPPING, AND STORAGE</u>	
	1. RECEIVING	33
	2. SHIPPING	33
	3. STORAGE	33
	<u>APPENDIX DISPLAY NAVIGATION GUIDES</u>	35

DFQ40K INSTRUCTION MANUAL

LIST OF FIGURES

	PAGE
Fig. 1. IDENTIFICATION LABEL.....	1
Fig. 2. OWNER WARRANTY REGISTRATION CARD	2
Fig. 3. LIMITED WARRANTY STATEMENT CARD.....	2
Fig. 4. DFQ40K TEST SET	5
Fig. 5. DFQ40K FRONT PANEL	7
Fig. 6. DFQ40K DISPLAY	9
Fig. 7. CORRECT BATTERIES POSITION	10
Fig. 8. AIRCRAFT INSULATION TEST CONFIGURATION.....	16
Fig. 9. AIRCRAFT CAPACITANCE TEST CONFIGURATION.....	18
Fig. 10. AIRCRAFT INDICATOR TEST CONFIGURATION	20
Fig. 11. AIRCRAFT SYSTEM CALIBRATION, PREFERRED CONFIGURATION	24
Fig. 12. AIRCRAFT SYSTEM CALIBRATION, ALTERNATE CONFIGURATION	26
Fig. 13. BENCH INSULATION TEST CONFIGURATION.....	29
Fig. 14. BENCH CAPACITANCE TEST CONFIGURATION	31
Fig. A1. OPERATION DISPLAY NAVIGATION GUIDE.....	37
Fig. A2. SETTING DISPLAY NAVIGATION GUIDE	39

DFQ40K INSTRUCTION MANUAL

INTRODUCTION

1. PUBLICATION BREAKDOWN

This publication contains the identification data, description, and operation procedures for the DIGITAL FUEL QUANTITY TEST SET, Model DFQ40K (hereafter referred to as the *Test Set*).

The manual is developed to address the Test Set which is specifically designed to meet the requirements for servicing AC capacitance-type Aircraft Fuel Quantity Systems. The basic manual provides information for the operation of the DFQ40K in typical sequence.

Each individual Aircraft Fuel Quantity System will require its own particular Adapter Cable(s) and specific instructions.

Contact the manufacturer for a listing of available Adapter Cables. Complete Fuel Quantity System Test and Calibration Instructions are furnished with most Adapter Cables.

2. INFORMATION PROVIDED WITH THE UNIT

Besides this Instruction Manual, the Test Set is provided with four items described below.

- A. The identification label, similar to Figure 1, is located above the handle of the Test Set case and provides the following information:

Manufacturer Name	
Designation of Equipment	
Equipment Part Number	
Equipment Model Number	Equipment Serial Number
Equipment Modification (if applicable)	Equipment Options (if applicable)

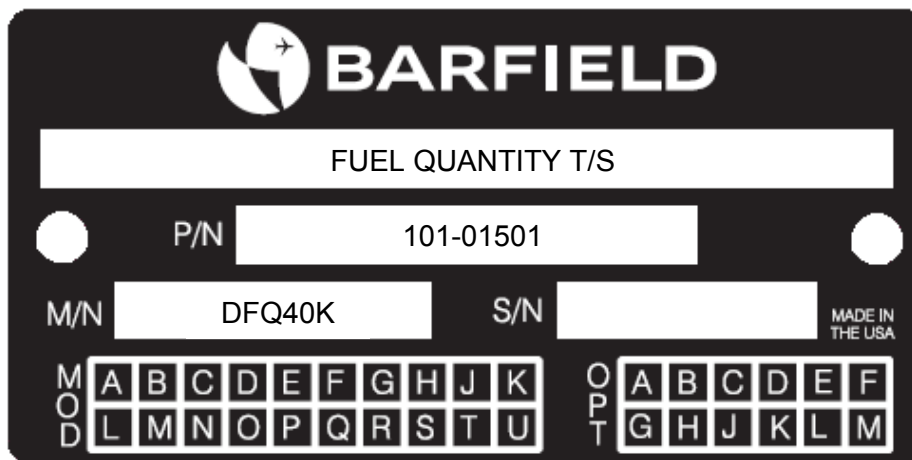

Figure 1 IDENTIFICATION LABEL

DFQ40K INSTRUCTION MANUAL

- B. The Owner's Warranty Registration card (Figure 2) is to be completed by the owner and returned to Barfield, Inc. within **ten (10) days** of purchase to ensure automatic update of printed matter and validation of warranty.

OWNER WARRANTY REGISTRATION
RETURNING THIS CARD COMPLETED ENABLES US TO KEEP YOU
AUTOMATICALLY INFORMED OF TECHNICAL UPDATES and VALIDATES YOUR WARRANTY.

NAME _____ TITLE _____
DEPARTMENT _____
COMPANY _____
ADDRESS _____
CITY _____ STATE _____ ZIP _____
P/N _____ S/N _____ MODEL # _____
PURCHASED FROM _____ DATE _____
AIRLINE REPAIR STATION OEM
OTHER _____

INFORMATION GIVEN ON THIS BARFIELD, INC. WARRANTY CARD IS AND WILL REMAIN
STRICTLY CONFIDENTIAL AND WILL NOT BE SHARED. OW-28 REV / 04.00

Figure 2 OWNER WARRANTY REGISTRATION CARD

- C. The Limited Warranty Statement (Figure 3) lists the manufacturer's obligation to the original purchaser.
- D. Each new or re-certified unit, is delivered with a Certificate that shows the date when the unit was tested by the manufacturer, its serial number, and when the next calibration is due. This Certificate confirms that the unit performed according to its design specifications.

3. RECERTIFICATION

The Barfield Digital Fuel Quantity Test Set (P/N 101-01501) has a one-year recertification requirement. Qualified technicians in a shop equipped with the necessary tooling, facilities, and Barfield-approved procedures must perform the maintenance required by this unit.

DFQ40K INSTRUCTION MANUAL

LIMITED ONE YEAR WARRANTY

BARFIELD INC. ("BARFIELD") warrants only to the original Purchaser of this product from BARFIELD or an authorized distributor that this product will be free from defects in material and workmanship under normal use and service for one year after date of purchase. BARFIELD reserves the right, before having any obligation under this limited warranty, to inspect the damaged BARFIELD product, and all costs of shipping the BARFIELD product to BARFIELD for inspection shall be borne solely by the Purchaser. In order to recover under this limited warranty, Purchaser must make claim to BARFIELD within 60 days of occurrence, and must present acceptable proof of original ownership (such as a purchase order, invoice, warranty card registration, or other documentation BARFIELD deems acceptable) for the product. BARFIELD, at its option, shall repair or replace the defective unit covered by this warranty. Please retain the dated sales receipt as evidence of the original purchaser's date of purchase. You will need it for any warranty service. In order to keep this limited warranty in effect, the product must have been handled and used as prescribed in the instructions accompanying this product. This limited warranty does not cover any damage due to accident, misuse, abuse or negligence. This limited warranty is non-transferable and does not apply to any purchaser who bought the product from a reseller or distributor not authorized by BARFIELD, including but not limited to purchases from internet sites. This warranty does not affect any other legal rights you may have by operation of law. Contact BARFIELD at www.Barfieldinc.com or customer service at (305) 894-5506 for warranty service procedures.

DISCLAIMER OF WARRANTY

EXCEPT FOR THE LIMITED WARRANTY PROVIDED HEREIN, TO THE EXTENT PERMITTED BY LAW, BARFIELD DISCLAIMS ALL WARRANTIES, EXPRESS OR IMPLIED, INCLUDING ALL WARRANTIES OF MERCHANTABILITY AND/OR FITNESS FOR A PARTICULAR PURPOSE. TO THE EXTENT THAT ANY IMPLIED WARRANTIES MAY NONETHELESS EXIST BY OPERATION OF LAW, ANY SUCH WARRANTIES ARE LIMITED TO THE DURATION OF THIS WARRANTY. SOME STATES/PROVINCES DO NOT ALLOW LIMITATIONS ON HOW LONG AN IMPLIED WARRANTY LASTS, SO THE ABOVE LIMITATIONS MAY NOT APPLY TO YOU.

LIMITATION OF LIABILITY

REPAIR OR REPLACEMENT OF THIS PRODUCT, AS PROVIDED HEREIN, IS YOUR EXCLUSIVE REMEDY. BARFIELD SHALL NOT BE LIABLE FOR ANY SPECIAL, INCIDENTAL OR CONSEQUENTIAL DAMAGES, INCLUDING, BUT NOT LIMITED TO, LOST REVENUES, LOST PROFITS, LOSS OF USE OF SOFTWARE, LOSS OR RECOVERY OF DATA, RENTAL OF REPLACEMENT EQUIPMENT, DOWNTIME, DAMAGE TO PROPERTY, AND THIRD-PARTY CLAIMS, ARISING OUT OF ANY THEORY OF RECOVERY, INCLUDING WARRANTY, CONTRACT, STATUTORY OR TORT. NOTWITHSTANDING THE TERM OF ANY LIMITED WARRANTY OR ANY WARRANTY IMPLIED BY LAW, OR IN THE EVENT THAT ANY LIMITED WARRANTY FAILS OF ITS ESSENTIAL PURPOSE, IN NO EVENT WILL BARFIELD'S ENTIRE LIABILITY EXCEED THE PURCHASE PRICE OF THIS PRODUCT. SOME STATES/PROVINCES DO NOT ALLOW THE EXCLUSION OR LIMITATION OF INCIDENTAL OR CONSEQUENTIAL DAMAGES, SO THE ABOVE LIMITATION OR EXCLUSION MAYNOT APPLY TO YOU. THIS WARRANTY GIVES YOU SPECIFIC LEGAL RIGHTS AND YOU MAY ALSO HAVE OTHER RIGHTS THAT VARY FROM STATE TO STATE AND PROVINCE TO PROVINCE.

BARFIELD INC.

4101 NW 29th Street

Miami, Florida 33142, USA

Form 7.5.3-13
Dated 09/01/2014, Rev. 1



AIRFRANCE
INDUSTRIES

KLM
Engineering & Maintenance

Figure 3 LIMITED WARRANTY STATEMENT

This page intentionally left blank.

CHAPTER 1: GENERAL INFORMATION

1. DESCRIPTION AND PURPOSE OF THE TEST SET

The BARFIELD, INC. DFQ40K (Fig. 4) is a Fuel Quantity Test Set (T/S) designed to test the aircraft Fuel Quantity Indicating System (FQIS) for insulation, capacitance and to test the operation and calibration of the indicating system. The Test Set is a portable unit enclosed in a ruggedized plastic carrying case.

The Test Set meets or exceeds the range of requirements for *wet* and *dry* tank measurement and calibration. Group or individual tank unit insulation resistance and capacitance measurements may also be performed.

Accuracy and reliability have been optimized with safety, portability, light weight, and the additional convenience of battery operation.



Figure 4 DFQ40K TEST SET

DFQ40K INSTRUCTION MANUAL

All measurement readings are presented on the multi-line, multi-font backlit LCD (Liquid Crystal Display).

Two digitally programmable capacitance simulators are provided for Tank and Compensator capacitances.

The potentials and currents introduced are limited to meet all safety specifications.

With proper Adapter Cables, a wide range of Aircraft Fuel Quantity Systems can be serviced in maintenance testing, troubleshooting, calibration, as well as cockpit or bench testing of the indicators.

By use of the soft keys F1 through F6, the measurement and calibration functions are provided.

With the exception of Adapter Cables, the Test Set contains the necessary interconnecting accessories for test and calibration of the Aircraft Fuel Quantity System as well as individual components' test and calibration.

Most aircraft fuel quantity adapter cables, specified by aircraft and / or system, from this as well as other manufacturers, are usable without modification. Adapter Cable configuration and connections vary considerably to accommodate the wide variety of Fuel Quantity Systems in use.

The user should first become familiar with the Test Set and its Accessory Lead Package as presented in this text. The actual tests to be performed and the procedures to be followed are dictated by the requirements of the particular Aircraft Fuel Quantity Indicating System and the Adapter Cables for that system will have their own set of procedures.

Refer to the appropriate maintenance manuals for specific procedures and calibration values.

2. TEST SET FEATURES

A. Carrying Case

- The Test Set is securely fixed to the Carrying Case, making them both a single entity, easy to carry and set up near to the system to be tested.
- Ergonomic handle allows carrying the Test Set like a suitcase.
- Fabricated from ruggedized plastic in yellow color for maximum strength and visibility, the case is airtight and dust –proof, and also includes space to carry this Manual.
- The lid section has been fitted with a pouch for the Accessory Lead Package. This lid is opened with two latches, and conveniently stays in place by means of two hinges.
- The front panel has two handles to facilitate moving the Test Set with the lid open.
- Two integral padlock openings for security, located close to the exterior handle.

DFQ40K INSTRUCTION MANUAL

B. Front Panel and Switching Functions

Pushbuttons:

On the Display / User Entry Module

The PWR (PoWeR) pushbutton is pressed and held to turn the DFQ40K on or off.

The BACK pushbutton is pressed to return back to the previous display screen.

The NEXT pushbutton is pressed to advance to the next set of options for the soft key menu system.

Pushbuttons F1 (Function 1) through F6 (Function 6) are pressed to select the corresponding option displayed above them.

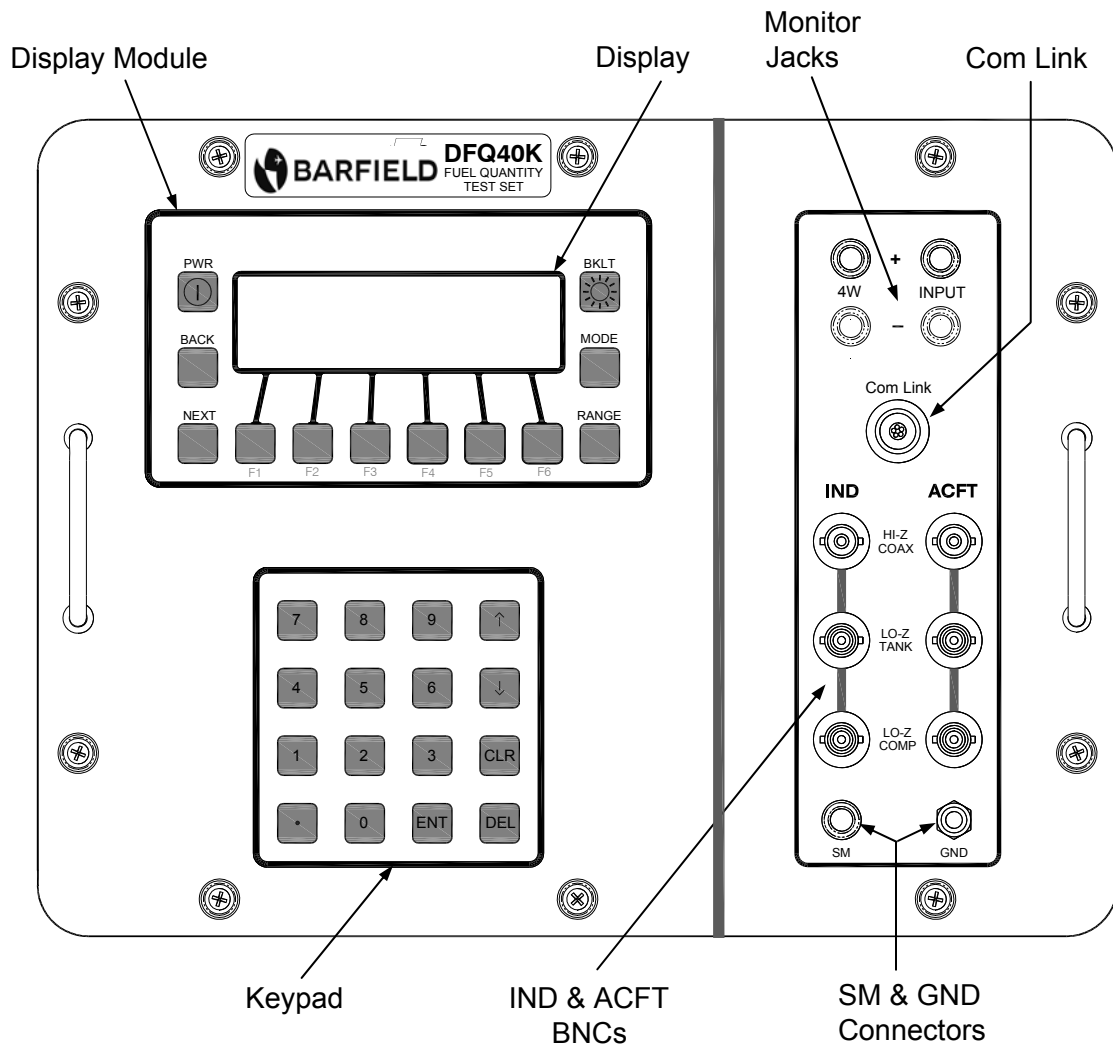

Figure 5 DFQ40K FRONT PANEL

DFQ40K INSTRUCTION MANUAL

The RANGE pushbutton is active for Resistance, Insulation Capacitance, and Capacitance Simulator Measurements. It is pressed to select and lock the specific range desired as an addition to the Auto Range option.

The MODE pushbutton is pressed to select alternate modes of operation within a given function. An example would be 2W or 4W when measuring resistance to select the 2 wire or 4 wire modes of operation respectively.

The BKLT (BackLighT) pushbutton is used to toggle the display backlight on or off.

On the Numeric Keypad

Pushbuttons 0 through 9 and "." are self-explanatory.

The ENT (ENTer) pushbutton is pressed to enter a value after it has been keyed in.

The DEL (DELeTe) pushbutton is pressed to delete the last digit keyed in.

The CLR (CleaR) pushbutton is pressed to delete the entire entry.

The ↑ (up) and ↓ (down) pushbuttons are used to increment or decrement the value entered.

Connections:

The "+" and "-" INPUT and the "+" and "-" 4W receptacles are banana jacks and provide the connection points for the Monitor tests. The Input jacks are used for resistance measurements, DC voltage measurements and for sourcing or measuring the Indicator drive current. The 4W jacks are used in conjunction with the Input jacks and are the sense lead input jacks for making 4-wire resistance measurements.

The ACFT HI-Z COAX, ACFT LO-Z TANK and ACFT LO-Z COMP receptacles are BNC connectors. They are used to connect the DFQ40K to leads proceeding from the AirCraFT (tank units) side of the aircraft interface adapter cable.

The IND HI-Z COAX, IND LO-Z TANK and IND LO-Z COMP receptacles are BNC connectors and are used to connect the DFQ40K to the leads proceeding from the INDicating side of the aircraft interface adapter cable.

The SM (Shield Monitor) receptacle is a banana jack and provides the connection point for the Shield Monitor test for aircraft which are so equipped.

The GND (GrouND) receptacle is a banana jack and provides the connection point for the chassis ground of the test set.

The panel connector labeled COM LINK will be used with the new generation of Smart Cables. These Cables will provide the DFQ40K the ability to read test data stored in the adapter cable specific to the aircraft type under test. This will make it possible for the DFQ40K to perform an Automated Test Routine (AUTO) on the

DFQ40K INSTRUCTION MANUAL

aircraft wiring and tank units at the push of a button, resulting in a PASS or FAIL message. Should the test result in a FAIL message, the test set will give clear indication as to the nature of the failure and likely source(s). This will greatly reduce the time required to test, troubleshoot and validate the system.

Digital Display:

The capacity of the backlit LCD display, is 8 lines by 40 characters (Fig. 6).

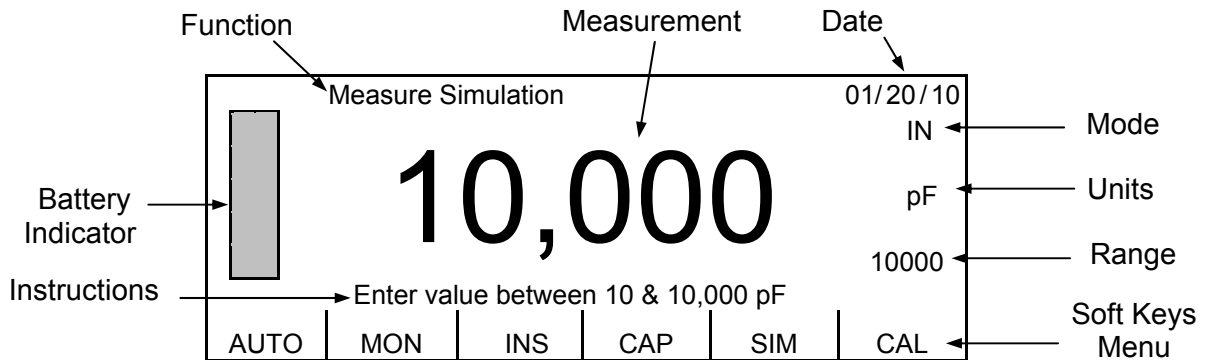

Figure 6 DFQ40K DISPLAY

The items shown in the display are as follows:

- Battery icon:** Bar graph of the remaining battery life
- Status line:** Shows the current function
- Measurement window:** Displays the measurement reading using 40,000 or 4,000 counts depending on function selected
- Date:** Shows the current date as month / day / year
- Mode:** Shows the current Mode of operation and toggles to alternate modes with each depression of the MODE pushbutton as applicable
- Units:** Displays the associated units of measurement
- Range:** Indicates whether the test set is in AUTO range or one of the available five ranges when in Resistance, Insulation or Capacitance Measure or in the Simulation function
- Soft keys menu windows:** In conjunction with the F1 through F6 function keys below serve as the means of configuring the test set for the desired function
- Instruction line:** Provides prompts to the user, giving alerts or brief instructions as applicable

DFQ40K INSTRUCTION MANUAL

3. **BATTERIES AND ACCESSORIES INFORMATION**

A. Battery Installation and Replacement

The user must ensure that only batteries of the proper type (Eveready Size "C" 1.5V Alkaline No. E93 or equivalent) are used and that the satisfactory battery condition is maintained. Whenever the BATTERY legend shown in the Display (Fig. 6) indicates depleted cells on the LCD, the batteries **MUST** be replaced.

To remove old batteries and to install new ones:

- (a) Before battery installation, test each one individually to assure maximum battery life.
- (b) Remove caps from the two battery holders in the BATTERY COMPARTMENT located on the rear of the Test Set.
- (c) If there are old batteries inside this compartment, remove them. Install (3) C-cells into each holder, observing polarity (+ end faces out), as shown in Fig. 7.
- (d) Replace the caps on the two battery holders.



Figure 7 CORRECT BATTERIES POSITION

CAUTION: The right position for **all 6 batteries** is with the **+ end facing outward**

DFQ40K INSTRUCTION MANUAL

B. Standard Accessory Lead Package, supplied with the Unit

The Standard Accessory Lead Package (P/N 101-01511) stored in the lid pouch, provides the cables and adapters required to perform a wide variety of Fuel Quantity System tests:

- (1) One set of three TEE adapters, red, white, and black: P/N 31-008.
- (2) Two adapter assemblies, polarized BNC to BNC: P/N 112-00009.
- (3) One lead, Ground alligator clip to stackable banana plug, black: P/N 101-01007.
- (4) One cable, mini alligator clip to BNC, HI-Z, red: P/N 101-01024
- (5) One cable, mini alligator clip to polarized BNC, LO-Z, black: P/N 101-01025
- (6) One cable, mini alligator clip to polarized BNC, Comp, white: P/N 101-01026
- (7) Two cables, Polarized BNC to BNC, one white and one black: P/N 101-01009.
- (8) One cable, BNC to BNC, red: P/N 101-01008.
- (9) One two-lead cable, banana plug ends, red and black: P/N 101-01010.

C. Additional accessories, available as special order

Certain specialized tests require accessories not included in the Standard Accessory Lead Package (P/N 101-01511). Additional items are provided under the Special Accessories Package (P/N 101-01516), as follows:

- (1) One set of three STRAIGHT adapters, red, white, and black: P/N 31-219.
- (2) Two caps, shorting plugs (without chains): P/N 310-00004.
- (3) One pair of leads, for the indicator test, P/N 101-01000.

For the Four Wire Resistance Measurement, cable P/N 101-01027 is available.

If required, contact Barfield Customer Service Dept., to order either one or both P/Ns.

- D. An accessory power cable, P/N 175-00252, is provided with DFQ40K units identified with P/N 101-01502. In contrast with P/N 101-01501, which is energized only by batteries, P/N 101-01502 can be energized by either batteries or 28 VDC from aircraft power through a 2 Pole-2 Wire Midget Twist-Lock connector. An internal circuit detects if aircraft power is present or not, to automatically deactivate or activate the batteries accordingly. This is the only difference between these two P/Ns 101-01501 and 101-01502. **Note:** Using external power on the P/N 101-01502 will **not** recharge the battery.

This page intentionally left blank.

CHAPTER 2 SPECIFICATIONS

1. TEST SET SPECIFICATIONS

Insulation Measurement

Parameter	Specification
Insulation Range	0.01 M Ω - 20.00 G Ω
Accuracy (40 M Ω , 400 M Ω & 4000 M Ω Ranges)	$\pm 5\% \pm 5$ counts
Accuracy (20.00 G Ω Range)	$\pm 10\% \pm 5$ counts

Capacitance Measurement

Parameter	Specification
Capacitance Range	0.01 pF - 40,000 pF
Accuracy (400 pF Range)	$\pm 0.1\% \pm 0.1$ pF
Accuracy (4000 and 40000 pF Ranges)	$\pm 0.1\% \pm 2$ counts

Capacitance Simulation

Parameter	Specification
Tank Range	10.0 pF - 10,000 pF
Compensator Range	10.0 pF - 1,000.0 pF
Accuracy	$\pm 0.1\% \pm 3$ counts

Distance to Fault

Parameter	Specification
DTF Range	0 pF - 40,000 pF
Accuracy	$\pm 0.1\% \pm 2$ pF

Low Resistance Measurement

Parameter	Specification
Resistance Range	0.001 Ω - 40,000 Ω
Accuracy 2-Wire / SM	$\pm 0.1\% \pm 5$ counts
Accuracy 4-Wire	$\pm 0.1\% \pm 2$ counts

Voltage Measurement

Parameter	Specification
Range	0.001 VDC - 40.000 VDC
Accuracy	$\pm 0.1\% \pm 0.002$ VDC

Indicator Test

Parameter	Specification
Current Range	1 μ A - 1,200 μ A
Accuracy	$\pm 0.1\% \pm 2$ μ A

DFQ40K INSTRUCTION MANUAL

2. PHYSICAL DATA

- A. Length: 13.4 in (34.0 cm)
- B. Width: 11.6 in (29.5 cm)
- C. Depth: 6.0 in (15.2 cm)
- D. Weight: 10.0 lbs (4.5 kg)

3. OPERATING TEMPERATURE RANGE

From -13°F (-25°C) to 131°F (55°C)

DFQ40K INSTRUCTION MANUAL

CHAPTER 3: OPERATION

NOTE: To perform the tests, the Test Set must be connected to an Adapter Cable, and the latter to the Aircraft. The Adapter Cable is specific to the Aircraft to be tested. Instructions presented in this manual are general by necessity, and the particular testing procedures are indicated in the information provided with each Adapter Cable, prepared as supplements to this manual. Contact Barfield, Inc., for a current list of Adapter Cables developed for this Test Set.

1. AIRCRAFT INSULATION TEST**A. Aircraft Preparation**

CAUTION: TANK UNIT INSULATION TESTS ARE NOT TO BE CARRIED OUT UNTIL FUEL TANKS HAVE BEEN EMPTIED AND PURGED. REFER TO SPECIFIC AIRCRAFT MAINTENANCE MANUALS FOR PROPER FUELING AND DEFUELING PROCEDURES OBSERVING PRECAUTIONS THEREIN.

(1) Defuel the Aircraft.

CAUTION: FUEL QUANTITY, REFUEL, AND DEFUEL POWER MUST BE OFF WHILE ACCESSING AND BEFORE ANY HARNESS, CABLE, OR CONNECTOR IS REMOVED. POWER MUST REMAIN OFF UNTIL CONNECTIONS ARE MADE AS SPECIFIED AND UNTIL POWER REQUIREMENT IS CALLED OUT.

(2) Open appropriate Fuel Quantity System circuit breaker(s).

CAUTION: REFER TO AIRCRAFT MAINTENANCE MANUAL FOR ACCESSING PROCEDURES, FOLLOW ALL PRECAUTIONS THEREIN.

(3) Gain access to the cockpit indicator or the appropriate Fuel Quantity System electrical connector(s) necessary for this procedure.**(4) Disconnect at the cockpit indicator or the appropriate electrical connector(s).****(5) It may be necessary to position an aircraft tank select switch and/or an Adapter Cable select switch for this procedure.****B. Connecting Test Set****(1) Position the equipment conveniently for the following procedures.****(2) Connect to the Test Set the Adapter Cable specific for the Aircraft being tested, as shown in Figure 8 or as directed in the Adapter Cable Instructions.****(3) Connect the Adapter Cable between the Indicator and the aircraft wiring plug.****(4) Connect the ground lead from the adapter (if so equipped) or from the Test Set **GND** receptacle, to a secure airframe ground.**

DFQ40K INSTRUCTION MANUAL

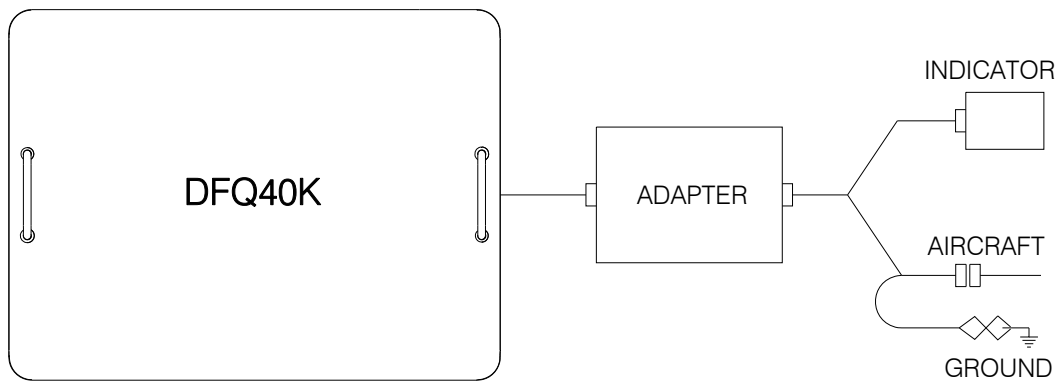

Figure 8 AIRCRAFT INSULATION TEST CONFIGURATION

C. Test Procedure

Refer to the specific Maintenance Manuals for proper procedures and calibration values.

- (1) Press PWR to turn test set ON.
- (2) Allow initialization to complete as displayed by the progress bar.
- (3) Press ENT to accept last used Frequency or key in new between 400 and 10,000Hz.
Example for 1000 Hz: On the keypad press “1”, then “0”, then “0”, then “0” then ENT.
- (4) Press F3 to select INSulation Measure.

AUTO	MON	INS	CAP	SIM	CAL
F1	F2	F3	F4	F5	F6

- (5) Press MODE to select 3T (default) or 2T as desired.
- (6) Press RANGE to select AUTO ranging (default) or 40M, 400M, 4,000M or 20GΩ range.
- (7) Press F1 for L/H (default), if not already highlighted.

L/H	L/S	L/G	H/G	H/S	S/G
F1	F2	F3	F4	F5	F6

- (8) Observe the LCD display until it shows its highest value, or a value exceeding the minimum specified. The test is considered satisfactory if the minimum is reached.
- (9) Press F2 for L/S.

L/H	L/S	L/G	H/G	H/S	S/G
F1	F2	F3	F4	F5	F6

- (10) The test is considered satisfactory if the minimum specified is reached.

DFQ40K INSTRUCTION MANUAL

- (11) Repeat the test by pressing F3 thru F6 for remaining points of testing.
- (12) Press NEXT to select COMPensator points of test.
- (13) Press F1 for L/C (default), if not already highlighted.

L/C	C/H	C/S	C/G		ST
F1	F2	F3	F4	F5	F6

- (14) The test is considered satisfactory if the minimum specified is reached.
- (15) Press F2 for C/H.

L/C	C/H	C/S	C/G		ST
F1	F2	F3	F4	F5	F6

- (16) The test is considered satisfactory if the minimum specified is reached.
- (17) Press F6 for Self Test at any time to ensure proper operation.

L/C	C/H	C/S	C/G		ST
F1	F2	F3	F4	F5	F6

- (18) This completes the AIRCRAFT INSULATION TEST.
- (19) Press PWR to turn test set OFF.
- (20) Disconnect the Adapter Cable from the Test Set.
- (21) Disconnect the Adapter Cable from the Aircraft and from the Indicator.
- (22) Return the aircraft to its original configuration.

2. AIRCRAFT CAPACITANCE TEST

A. Aircraft Preparation

CAUTION: TANK UNIT CAPACITANCE TESTS ARE NOT TO BE CARRIED OUT UNTIL FUEL TANKS HAVE BEEN EMPTIED AND PURGED. REFER TO SPECIFIC AIRCRAFT MAINTENANCE MANUALS FOR PROPER FUELING AND DEFUELING PROCEDURES OBSERVING PRECAUTIONS THEREIN.

- (1) Defuel the Aircraft.

CAUTION: FUEL QUANTITY, REFUEL, AND DEFUEL POWER MUST BE OFF WHILE ACCESSING AND BEFORE ANY HARNESS, CABLE, OR CONNECTOR IS REMOVED. POWER MUST REMAIN OFF UNTIL CONNECTIONS ARE MADE AS SPECIFIED AND UNTIL POWER REQUIREMENT IS CALLED OUT.

DFQ40K INSTRUCTION MANUAL

- (2) Open appropriate Fuel Quantity System circuit breaker(s).

CAUTION: REFER TO AIRCRAFT MAINTENANCE MANUAL FOR ACCESSING PROCEDURES, FOLLOW ALL PRECAUTIONS THEREIN.

- (3) Gain access to the cockpit indicator or the appropriate Fuel Quantity System electrical connector(s) necessary for this procedure.
- (4) Disconnect at the cockpit indicator or the appropriate electrical connector(s).
- (5) It may be necessary to position an aircraft tank select switch and/or an Adapter Cable select switch for this procedure.

B. Connecting Test Set

- (1) Position the equipment conveniently for the following procedures.
- (2) Connect to the Test Set the Adapter Cable specific for the Aircraft being tested, as shown in Figure 9 or as directed in the Adapter Cable Instructions.
- (3) Connect the Adapter Cable between the Indicator and the aircraft wiring plug.
- (4) Connect the ground lead from the adapter (if so equipped) or from the Test Set **GND** receptacle, to a secure airframe ground.

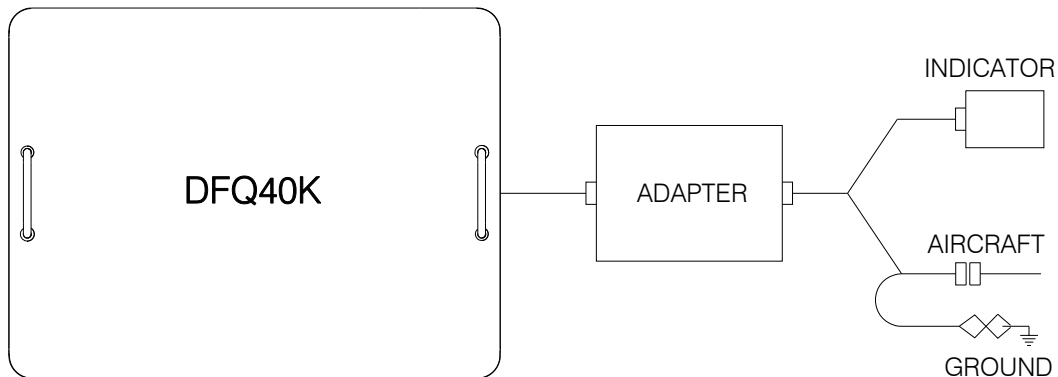

Figure 9 AIRCRAFT CAPACITANCE TEST CONFIGURATION

C. Test Procedure

Refer to the specific Maintenance Manuals for proper procedures and calibration values.

- (1) Press PWR to turn test set ON.
- (2) Allow initialization to complete.
- (3) Press ENT to accept last used Frequency or key in new frequency, then press ENT.
- (4) Press F4 to select CAPacitance Measure.

AUTO	MON	INS	CAP	SIM	CAL
F1	F2	F3	F4	F5	F6

DFQ40K INSTRUCTION MANUAL

- (5) Press RANGE to select AUTO ranging or 400 pF, 4,000 pF or 40,000 pF range.
- (6) Press F1 to measure TANK capacitance, if not already highlighted.

NOTE: Press F5 to Zero adapter cable stray capacitance. Subsequent measurements are offset by the stored value.

TANK	COMP	DTF		ZERO	ST
F1	F2	F3	F4	F5	F6

- (7) Observe the display reading and verify if the value is within specified tolerance.
- (8) Press F2 to test the Compensator.

TANK	COMP	DTF		ZERO	ST
F1	F2	F3	F4	F5	F6

- (9) Observe the display reading and verify the value is within specified tolerance.
- (10) Press F3 to test the Distance To Fault of the HI-Z shield.

TANK	COMP	DTF		ZERO	ST
F1	F2	F3	F4	F5	F6

- (11) Press MODE to select between pF or Feet or Meters.
- (12) Observe the display reading and verify if the value is within specified tolerance.
- (13) Press F6 for Self Test at any time to ensure proper operation.

TANK	COMP	DTF		ZERO	ST
F1	F2	F3	F4	F5	F6

- (14) This completes the AIRCRAFT CAPACITANCE TEST.
- (15) Press PWR to turn test set OFF.
- (16) Disconnect the Adapter Cable from the Test Set.
- (17) Disconnect the Adapter Cable from the Aircraft and from the Indicator.
- (18) Return the aircraft to its original configuration.

DFQ40K INSTRUCTION MANUAL

3. INDICATOR TEST

The Fuel Quantity Indicator may contain all the system measurement circuitry or a major portion may be contained in a separate unit referred to as a signal conditioner or amplifier. The procedure is similar, only the location of the units and their adjustments will be affected.

CAUTION: THE PROCEDURE INDICATED IN THIS SECTION IS NOT FOR A CALIBRATION. ANY ADJUSTMENT PERFORMED HERE MUST THEN BE FOLLOWED BY AN ACTUAL CALIBRATION.

A. Aircraft Preparation

- (1) The Aircraft does not need to be defueled for this test. The level of fuel is irrelevant.

CAUTION: FUEL QUANTITY, REFUEL, AND DEFUEL POWER MUST BE TURNED OFF WHILE ACCESSING AND BEFORE ANY HARNESS, CABLE OR CONNECTOR IS REMOVED. POWER MUST REMAIN OFF UNTIL CONNECTIONS ARE MADE AS SPECIFIED AND UNTIL POWER REQUIREMENT IS CALLED OUT.

- (2) Open appropriate Fuel Quantity System circuit breaker(s).

CAUTION: REFER TO AIRCRAFT MAINTENANCE MANUAL FOR ACCESSING PROCEDURES, FOLLOW ALL PRECAUTIONS THEREIN.

- (3) Gain access to the cockpit indicator or the appropriate Fuel Quantity System electrical connector(s) necessary for this procedure.
- (4) Disconnect at the cockpit indicator or the appropriate electrical connector(s).

B. Connecting Test Set

- (1) Position the equipment conveniently for the following procedures.
- (2) Connect to the Test Set the Adapter Cable specific for the Aircraft being tested, as shown in Figure 10 or as directed in the Adapter Cable Instructions.
- (3) Connect the Adapter Cable between the Indicator and the aircraft wiring plug.
- (4) Connect the ground lead from the adapter (if so equipped) or from the Test Set **GND** receptacle, to a good airframe ground.

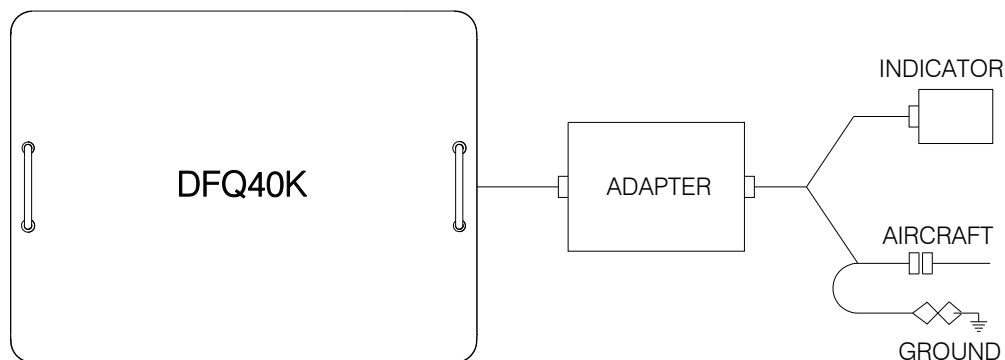

Figure 10 AIRCRAFT INDICATOR TEST CONFIGURATION

DFQ40K INSTRUCTION MANUAL

C. Test Procedure

Refer to the specific Maintenance Manuals for proper procedures and calibration values.

- (1) Press PWR to turn test set ON.
- (2) Allow initialization to complete.
- (3) Press ENT to accept last used Frequency or key in new frequency, then press ENT.
- (4) Press F5 to select the SIMulator function.

AUTO	MON	INS	CAP	SIM	CAL
F1	F2	F3	F4	F5	F6

- (5) Press MODE for IN (default) if the COMPensator simulator is needed.
- (6) Press F1 to select TANK simulator (default), if not highlighted.

TANK	COMP				CAL
F1	F2	F3	F4	F5	F6

- (7) Press RANGE to select 4,000 pF or 10,000 pF as desired.
- (8) Using the keypad, enter the Empty TANK capacitance.
Example for 123.4 pF: press “1”, then “2”, then “3”, then “.”, then “4” then ENT
- (9) Press F2 to select COMPensator.

TANK	COMP				CAL
F1	F2	F3	F4	F5	F6

- (10) Using the keypad, enter the Empty COMP capacitance.
- (11) Press BACK to return to Main screen.
- (12) Press F6 to select CAL.

AUTO	MON	INS	CAP	SIM	CAL
F1	F2	F3	F4	F5	F6

- (13) Press F1 to select SIM (default), if not highlighted.

SIM	ACFT	A & S		TANK	COMP
F1	F2	F3	F4	F5	F6

- (14) Close appropriate aircraft Fuel Quantity System circuit breaker(s).
- (15) Adjust the Empty adjustment screw for a ZERO or EMPTY indicator reading.
- (16) Press BACK to return to Main screen.
- (17) Press F5 to select the SIMulator function.

DFQ40K INSTRUCTION MANUAL

(18) Press F1 to select TANK.

TANK	COMP				CAL
F1	F2	F3	F4	F5	F6

(19) Using the keypad enter the Full TANK capacitance.

(20) If the compensator Full capacitance value is not the same as its Empty value, then press F2 and enter FULL Compensator value.

(21) Press BACK to return to Main screen.

(22) Press F6 to select CAL.

AUTO	MON	INS	CAP	SIM	CAL
F1	F2	F3	F4	F5	F6

(23) Adjust the Full adjustment screw to achieve a correct indicator reading.

(24) With some systems there may be an interaction between the Empty and Full adjustments, therefore it will be necessary to repeat the Empty and Full adjustments until no further improvements can be made.

(25) Once the Empty and Full adjustments are finalized, an indicator linearity test may be accomplished. Refer to the appropriate Maintenance Manuals for capacitance values between Empty and Full, to verify indicator linearity.

(26) This completes the INDICATOR TEST.

(27) Open appropriate Fuel Quantity System circuit breaker(s).

(28) Press PWR to turn test set OFF.

(29) Disconnect the Adapter Cable from the Test Set.

(30) Disconnect the Adapter Cable from the Aircraft and from the Indicator.

(31) Return the Aircraft to its original configuration.

DFQ40K INSTRUCTION MANUAL

4. SYSTEM CALIBRATION, PREFERRED (DRY TANK)

Insulation, capacitance, and all components of the system should be tested with their integrity proven before attempting system calibration.

A. Aircraft Preparation

If time or facilities do not permit draining of the tanks, the alternate method may be used in most instances.

CAUTION: THIS PROCEDURE CANNOT BE CARRIED OUT UNTIL FUEL TANKS HAVE BEEN EMPTIED AND PURGED. REFER TO APPROPRIATE AIRCRAFT MAINTENANCE MANUALS FOR PROPER FUELING AND DEFUELING PROCEDURES, OBSERVING PRECAUTIONS THEREIN.

(1) Defuel the Aircraft.

CAUTION: FUEL QUANTITY, REFUEL, AND DEFUEL POWER MUST BE TURNED OFF WHILE ACCESSING AND BEFORE ANY HARNESSSES, CABLES, OR CONNECTORS ARE REMOVED. POWER MUST REMAIN OFF UNTIL CONNECTIONS ARE MADE, AS SPECIFIED AND UNTIL POWER REQUIREMENT IS CALLED OUT.

(2) Open appropriate Fuel Quantity System circuit breaker(s).

CAUTION: REFER TO AIRCRAFT MAINTENANCE MANUAL FOR ACCESSING PROCEDURES, FOLLOW ALL PRECAUTIONS THEREIN.

(3) Gain access to the cockpit indicator or the appropriate Fuel Quantity System electrical connector(s) necessary for this procedure.**(4) Disconnect at the cockpit indicator or the appropriate electrical connector(s).****(5) It may be necessary to position an aircraft tank select switch and/or an Adapter Cable select switch for this procedure.****B. Connecting Test Set****(1) Position the equipment conveniently for the following procedures.****(2) Connect to the Test Set the Adapter Cable specific for the Aircraft being tested, as shown in Figure 11 or as directed in the Adapter Cable Instructions.****(3) Connect the Adapter Cable between the Indicator and the aircraft wiring plug.****(4) Connect the ground lead from the adapter (if so equipped) or from the Test Set **GND** receptacle, to a secure airframe ground.**

DFQ40K INSTRUCTION MANUAL

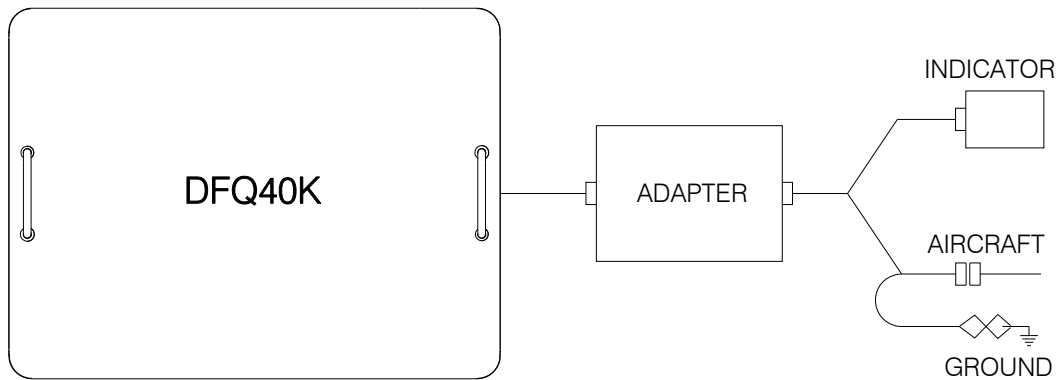

Figure 11 AIRCRAFT SYSTEM CALIBRATION, PREFERRED CONFIGURATION

C. Test Procedure

Refer to the specific Maintenance Manuals for proper procedures and calibration values.

- (1) Press PWR to turn test set ON.
- (2) Allow initialization to complete.
- (3) Press ENT to accept last used Frequency or key in new frequency, then press ENT.
- (4) Press F5 to select the SIMulator function.

AUTO	MON	INS	CAP	SIM	CAL
F1	F2	F3	F4	F5	F6

- (5) Press F1 to select TANK if not defaulted to.

TANK	COMP				CAL
F1	F2	F3	F4	F5	F6

- (6) Press MODE for IN if the compensator simulator is required.
- (7) Press RANGE to select 4,000 pF or 10,000 pF as desired.
- (8) Using the keypad, enter the ADD FOR FULL TANK capacitance.
Example for 123.4 pF: press “1”, then “2”, then “3”, then “.”, then “4” then ENT.
- (9) If the Compensator has an ADD FOR FULL value, press F2 to select COMPensator; if not go to step 11.

TANK	COMP				CAL
F1	F2	F3	F4	F5	F6

- (10) Using the keypad, enter the ADD FOR FULL COMP capacitance.
- (11) Press BACK to return to Main screen.

DFQ40K INSTRUCTION MANUAL

(12) Press F6 to select CAL.

AUTO	MON	INS	CAP	SIM	CAL
F1	F2	F3	F4	F5	F6

(13) Press F2 to select ACFT.

SIM	ACFT	A & S			
F1	F2	F3	F4	F5	F6

(14) Close appropriate Fuel Quantity System circuit breaker(s).

(15) Adjust the Empty adjustment screw for a ZERO or EMPTY indicator reading.

(16) Press F3 to select A & S (Aircraft & Simulator(s))

SIM	ACFT	A & S		TANK	COMP
F1	F2	F3	F4	F5	F6

(17) Adjust the Full adjustment screw to achieve a correct indicator reading.

(18) With some systems there may be an interaction between the Empty and Full adjustments; therefore, it may be necessary to repeat the Empty and Full adjustments until no further improvements can be made.

(19) This completes the SYSTEM CALIBRATION, PREFERRED.

(20) Open appropriate Fuel Quantity System circuit breaker(s).

(21) Press PWR to turn test set OFF.

(22) Disconnect the Adapter Cable from the Test Set.

(23) Disconnect the Adapter Cable from the Aircraft and from the Indicator.

(24) Return the Aircraft to its original configuration.

DFQ40K INSTRUCTION MANUAL

5. SYSTEM CALIBRATION, ALTERNATE (WET TANK)

The tanks may have any amount of fuel. This procedure yields a limited accuracy and should be followed by the preferred calibration at the next opportune time. The Fuel Quantity Indicator may contain all the system measurement circuitry or a major portion may be contained in separate units referred to as signal conditioners or amplifiers. The procedure is similar, only the location of the units and their adjustments will be affected.

A. Aircraft Preparation

- (1) The Aircraft does not have to be defueled for this test.

CAUTION: FUEL QUANTITY, REFUEL, AND DEFUEL POWER MUST BE TURNED OFF WHILE ACCESSING AND BEFORE ANY HARNESS, CABLE OR CONNECTOR IS REMOVED. POWER MUST REMAIN OFF UNTIL CONNECTIONS ARE MADE AS SPECIFIED AND UNTIL POWER REQUIREMENT IS CALLED OUT.

- (2) Open appropriate Fuel Quantity System circuit breaker(s).

CAUTION: REFER TO AIRCRAFT MAINTENANCE MANUAL FOR ACCESSING PROCEDURES, FOLLOW ALL PRECAUTIONS THEREIN.

- (3) Gain access to the cockpit indicator or the appropriate Fuel Quantity System electrical connector(s) necessary for this procedure.
- (4) Disconnect at the cockpit indicator or the appropriate electrical connector(s).

B. Connecting Test Set

- (1) Locate the equipment conveniently for the following procedures.
- (2) Connect to the Test Set the Adapter Cable specific for the Aircraft being tested, as shown in Figure 12 or as directed in the Adapter Cable Instructions.
- (3) Connect the Adapter Cable between the Indicator and the aircraft wiring plug.
- (4) Connect the ground lead from the adapter (if so equipped) or from the Test Set **GND** receptacle, to a secure airframe ground.

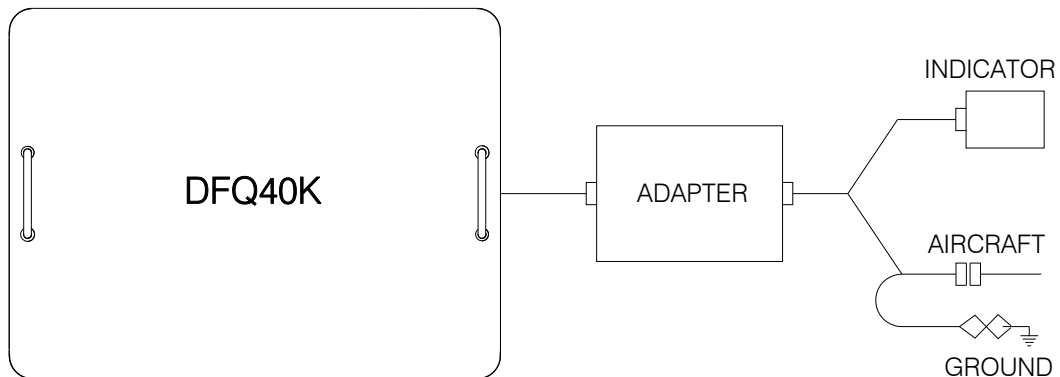

Figure 12 AIRCRAFT SYSTEM CALIBRATION, ALTERNATE CONFIGURATION

DFQ40K INSTRUCTION MANUAL

C. Test Procedure

Refer to the specific Maintenance Manuals for proper procedures and calibration values.

- (1) Press PWR to turn test set ON.
- (2) Allow initialization to complete.
- (3) Press ENT to accept last used frequency or key in new frequency, then press ENT.
- (4) Press F5 to select the SIMulator function.

AUTO	MON	INS	CAP	SIM	CAL
F1	F2	F3	F4	F5	F6

- (5) Press MODE for IN (default) if the COMPensator simulator is needed.
- (6) Press F1 to select TANK simulator (default), if not highlighted.

TANK	COMP				CAL
F1	F2	F3	F4	F5	F6

- (7) Press RANGE to select 4,000 pF or 10,000 pF as desired.
- (8) Using the keypad enter the Empty TANK capacitance.
Example for 123.4 pF: press “1”, then “2”, then “3”, then “.”, then “4”, then ENT
- (9) Press F2 to select COMPensator.

TANK	COMP				CAL
F1	F2	F3	F4	F5	F6

- (10) Using the keypad enter the Empty COMP capacitance.
- (11) Press BACK to return to Main screen.
- (12) Press F6 to select CAL.

AUTO	MON	INS	CAP	SIM	CAL
F1	F2	F3	F4	F5	F6

- (13) Press F1 to select SIM (default), if not highlighted.

SIM	ACFT	A & S		TANK	COMP
F1	F2	F3	F4	F5	F6

- (14) Close appropriate aircraft Fuel Quantity System circuit breaker(s).
- (15) Adjust the empty adjustment screw for a ZERO or EMPTY indicator reading.
- (16) Press BACK to return to Main screen.

- (17) Press F1 to select TANK.

DFQ40K INSTRUCTION MANUAL

TANK	COMP				CAL
F1	F2	F3	F4	F5	F6

- (18) Using the keypad enter the Full TANK capacitance.
- (19) If the compensator Full capacitance value is not the same as its Empty value, then press F2 and enter FULL Compensator value.
- (20) Press BACK to return to Main screen.
- (21) Press F6 to select CAL.

AUTO	MON	INS	CAP	SIM	CAL
F1	F2	F3	F4	F5	F6

- (22) Adjust the Full adjustment screw to achieve a correct indicator reading.
- (23) With some systems there may be an interaction between the Empty and Full adjustments; therefore, it will be necessary to repeat the Empty *and* Full adjustments until no further improvements can be made.
- (24) Once the Empty and Full adjustments are finalized, an indicator linearity test may be accomplished. Refer to the appropriate Maintenance Manuals for capacitance values between Empty and Full to verify indicator linearity.
- (23) This completes the INDICATOR TEST.
- (24) Open appropriate Fuel Quantity System circuit breaker(s).
- (25) Press PWR to turn test set OFF.
- (26) Disconnect the Adapter Cable from the Test Set.
- (27) Disconnect the Adapter Cable from the Aircraft and from the Indicator.
- (28) Return the Aircraft to its original configuration.

6. BENCH TEST PROBE INSULATION

A. Connecting Test Set

- (1) Position the proper equipment for the following procedures.
- (2) Connect the BNC to mini alligator clip leads between the Test Set ACFT jacks and the associated Probe terminals. Refer to Figure 13.
- (3) Connect the ground lead from the Test Set **GND** receptacle to the probe mounting flange. Refer to Figure 13.

DFQ40K INSTRUCTION MANUAL

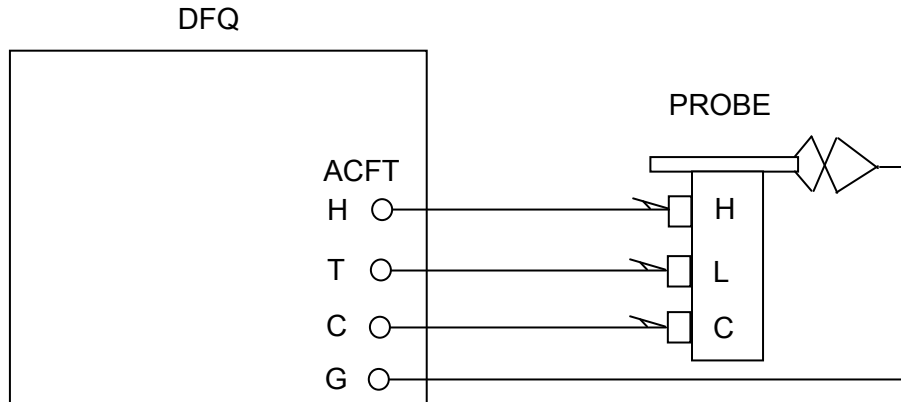

Figure 13 BENCH INSULATION TEST CONFIGURATION

B. Test Procedure

Refer to the appropriate Maintenance Manuals for specific values.

- (1) Press PW R to turn test set ON.
- (2) Allow initialization to complete.
- (3) Press ENT to accept last used Frequency or key in new frequency, then press ENT.
- (4) Press F3 to select INSulation Measure.

AUTO	MON	INS	CAP	SIM	CAL
F1	F2	F3	F4	F5	F6

- (5) Press MODE to select 3T (default) or 2T as desired.
- (6) Press RANGE to select AUTO ranging (default) or 40M, 400M, 4,000M or 20GΩ range.
- (7) Press F1 for L/H (default), if not already highlighted.

L/H	L/S	L/G	H/G	H/S	S/G
F1	F2	F3	F4	F5	F6

- (8) Observe the LCD display until it displays its highest value or a value exceeding the minimum specified. The test is considered satisfactory if this minimum is reached.
- (9) Press F2 for L/S.

L/H	L/S	L/G	H/G	H/S	S/G
F1	F2	F3	F4	F5	F6

- (10) The test is considered satisfactory if the minimum specified is reached.
- (11) Repeat the test by pressing F3 through F6 for remaining points of testing.

DFQ40K INSTRUCTION MANUAL

(12) Press NEXT to select COMPensator points of test.

(13) Press F1 for L/C, if not already highlighted.

L/C	C/H	C/S	C/G		ST
F1	F2	F3	F4	F5	F6

(14) The test is considered satisfactory if the minimum specified is reached.

(15) Repeat the test by pressing F2 through F4.

L/C	C/H	C/S	C/G		ST
F1	F2	F3	F4	F5	F6

(16) The test is considered satisfactory if the minimum specified is reached.

(17) Press F6 for Self Test at any time to ensure proper operation.

L/C	C/H	C/S	C/G		ST
F1	F2	F3	F4	F5	F6

(18) This completes the BENCH INSULATION TEST.

(19) Press PWR to turn test set OFF.

(20) Disconnect the leads from the Test Set.

(21) Disconnect the leads from the Probe.

7. BENCH TEST PROBE CAPACITANCE

A. Connecting Test Set

- (1) Position the proper equipment for the following procedures.
- (2) Connect the BNC to mini alligator clip leads between the Test Set ACFT jacks and the associated Probe terminals. Refer to Figure 14.
- (3) Connect the ground lead from the Test Set **GND** receptacle to the probe mounting flange. Refer to Figure 14.

DFQ40K INSTRUCTION MANUAL

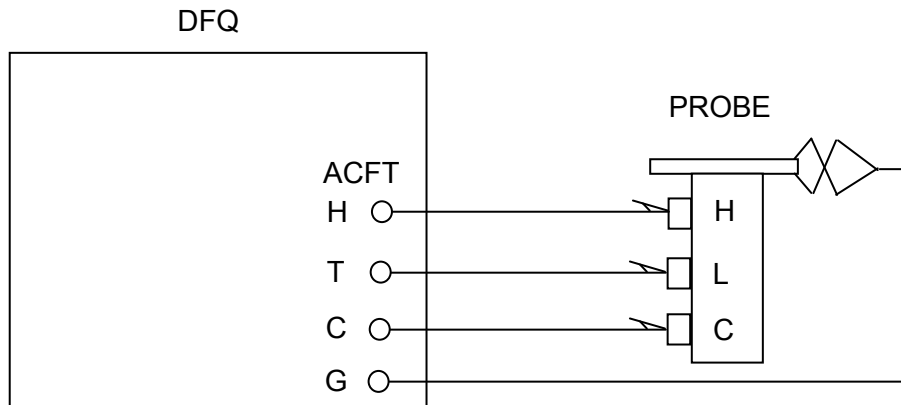

Figure 14 BENCH CAPACITANCE TEST CONFIGURATION

B. Test Procedure

Refer to the appropriate Maintenance Manuals for specific values.

- (1) Press PWR to turn test set ON.
- (2) Allow initialization to complete.
- (3) Press ENT to accept last used frequency or key in new frequency, then press ENT.
- (4) Press F4 to select CAPacitance Measure.

AUTO	MON	INS	CAP	SIM	CAL
F1	F2	F3	F4	F5	F6

- (5) Press RANGE to select AUTO ranging or 400 pF, 4,000 pF or 40,000 pF range.
- (6) Press F1 to measure TANK capacitance, if not already highlighted.

TANK	COMP	DTF		ZERO	ST
F1	F2	F3	F4	F5	F6

- (7) Observe the display reading and verify if the value is within specified tolerance.
- (8) Press F2 to test the Compensator.

TANK	COMP	DTF		ZERO	ST
F1	F2	F3	F4	F5	F6

- (9) Observe the display reading and verify if the value is within specified tolerance.
- (10) Press F6 for Self Test at any time to ensure proper operation.

TANK	COMP	DTF		ZERO	ST
F1	F2	F3	F4	F5	F6

DFQ40K INSTRUCTION MANUAL

- (11) This completes the BENCH CAPACITANCE TEST.
- (12) Press PWR to turn test set OFF.
- (13) Disconnect the leads from the Test Set.
- (14) Disconnect the leads from the Probe.

SECTION 4: RECEIVING, SHIPPING AND STORAGE

1. RECEIVING

No special unpacking procedures are necessary. It is recommended that the factory shipping container and packing materials be retained should it become necessary, for any reason, to reship the Test Set.

It is also recommended that the Test Set and its carrying case be carefully inspected for damage. If damaged, immediately notify the carrier and the manufacturer.

2. SHIPPING

Use standard delicate electronic equipment packaging procedures when packing the Test Set for reshipment.

3. STORAGE

- A. Remove the Batteries and store separately.
- B. Place a four ounce bag of desiccant inside the container.
- C. Close and latch the cover.
- D. Store in a cool dry place.

Should the Test Set become exposed to moisture or very high humidity: dry as soon as possible and temporarily store in a dehumidified area.

This page intentionally left blank.

APPENDIX

DISPLAY NAVIGATION GUIDES

This page intentionally left blank.

DFQ40K INSTRUCTION MANUAL

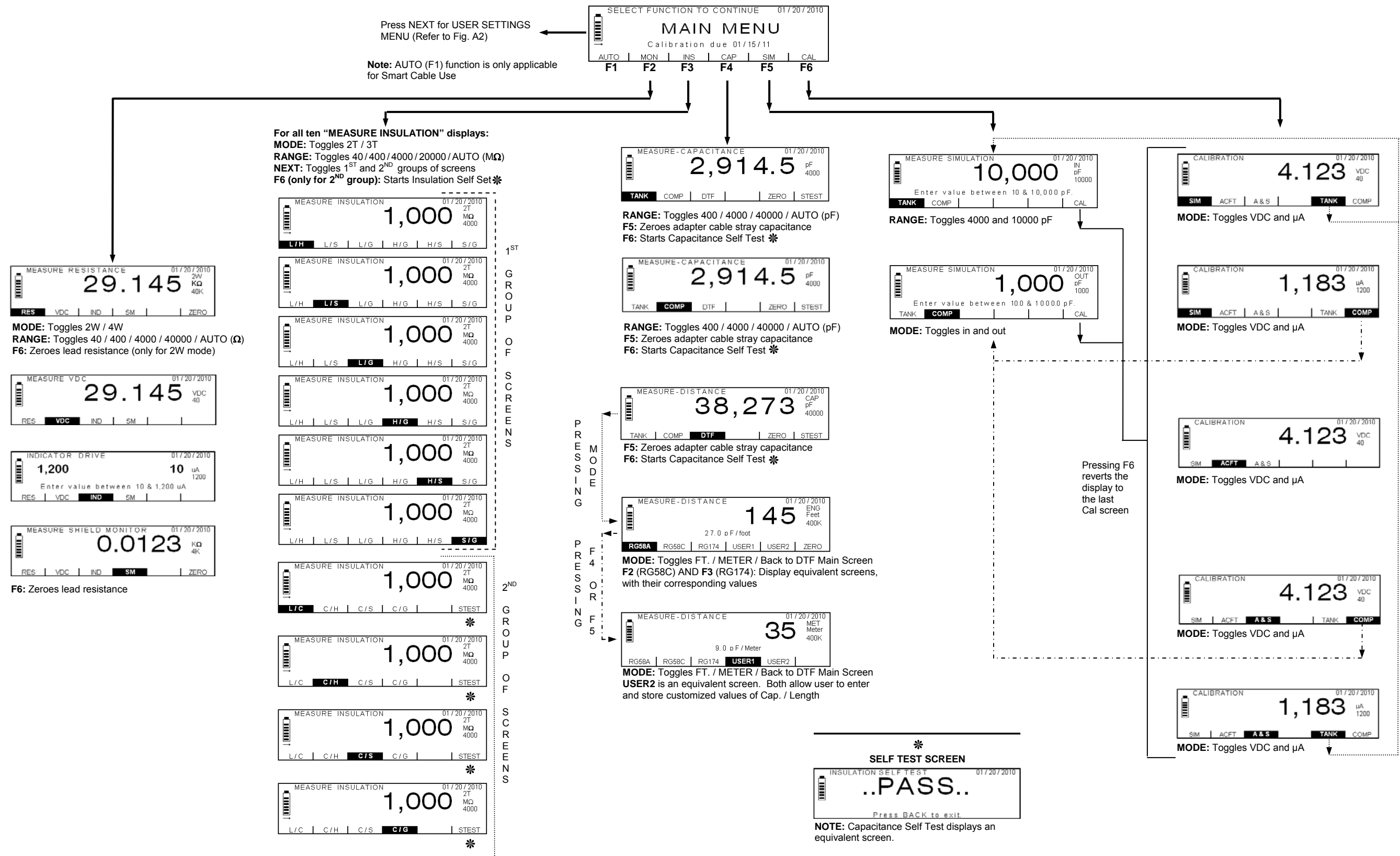

Figure A1 OPERATION DISPLAYS NAVIGATION GUIDE

This page intentionally left blank.

DFQ40K INSTRUCTION MANUAL

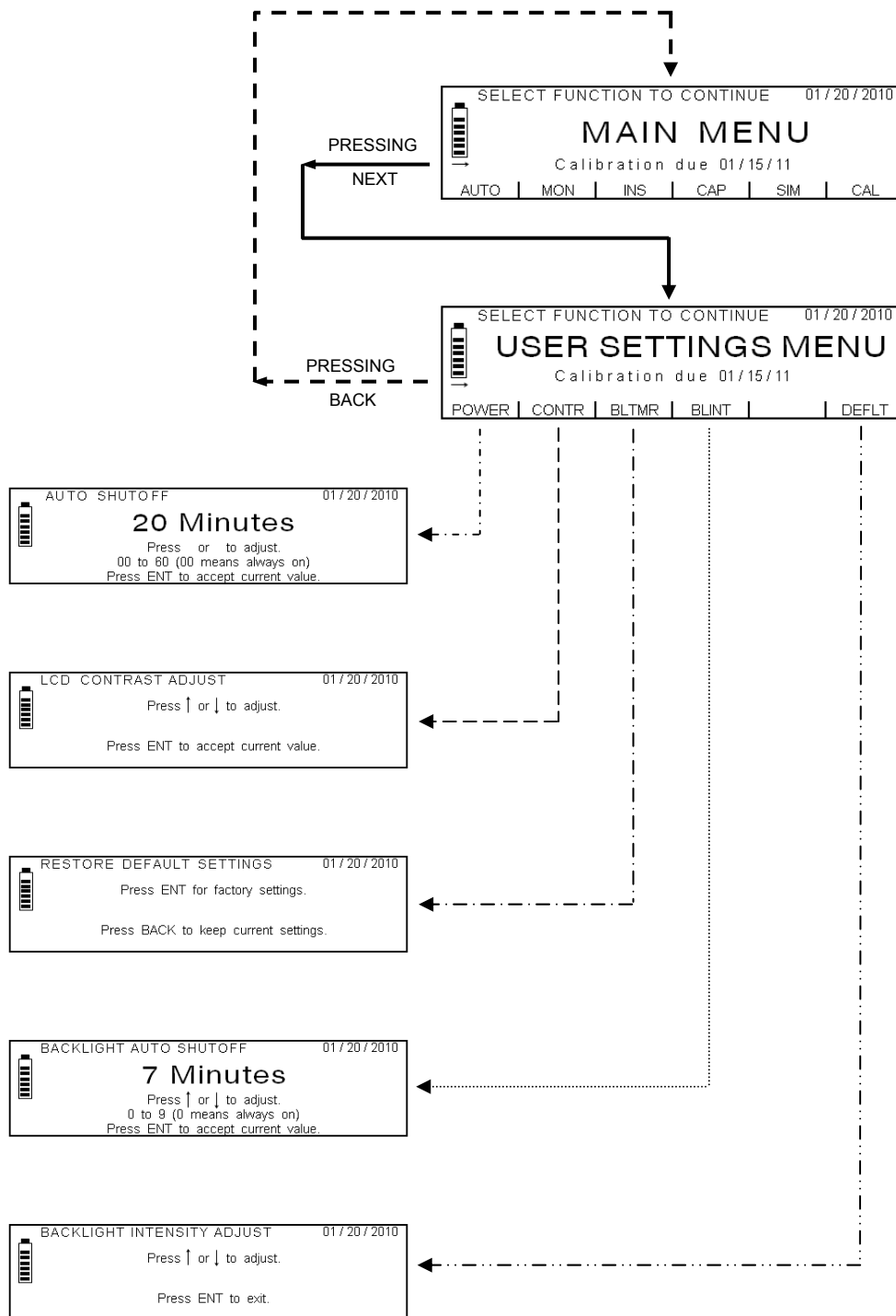

Figure A2 SETTINGS DISPLAYS NAVIGATION GUIDE